

**Public Notice of ARG590001 AFIN 51-00164  
C & H Hog Farm**

This is to give notice that the Arkansas Department of Environmental Quality (ADEQ) Water Division, 5301 Northshore Drive, North Little Rock, Arkansas 72118-5317 at telephone number (501) 682-0648, is providing a Public Comment period for the proposed draft modification of coverage for the applicant listed below under the Concentrated Animal Feeding Operation General Permit, ARG590000. The Notice of Intent (NOI) and Design Plans were received on May 7, 2015 with additional information received May 19, 2015. The facility is requesting to modify the Waste Storage Ponds to install pond liners in Waste Storage Ponds 1 and 2 as well as install a methane flare system and cover on Waste Storage Pond 1.

Only the requested modification to install pond liners in Waste Storage Ponds 1 and 2 as well as to install a methane flare system and cover on Waste Storage Pond 1 are open for comment.

Applicant: C & H Hog Farm. Location: HC 72 Box 10, Mount Judea, AR 72655; Latitude: 35° 55' 13.6" N Longitude: 93° 4' 51.0" W in Newton County.

The public notice of the Design Plans and NOI will be available on the Department's website at the following web address beginning July 8, 2015.

[http://www.adeq.state.ar.us/water/branch\\_permits/general\\_permits/generalpermitspn/arg590000\\_generalpermitspn.aspx](http://www.adeq.state.ar.us/water/branch_permits/general_permits/generalpermitspn/arg590000_generalpermitspn.aspx)

Written comments will be accepted during the Public Comment period, which will begin on July 8, 2015, and end on August 7, 2015 at 4:30 p.m. Central Time. All persons who wish to comment on ADEQ's draft permitting decision must submit written comments to ADEQ, along with their name and mailing address, during the Public Comment period. If the last day of the comment period is a Saturday, Sunday or legal holiday, the public comment period shall expire on the next day that is not a Saturday, Sunday or legal holiday.

After the Public Comment period, ADEQ will issue a final decision on the request to modify the Waste Storage Ponds. ADEQ will notify each person who has submitted Written comments and/or requested notice of the final decision.

ADEQ's contact for submitting Written Comments or requesting information regarding the NMP and NOI, is the Permits Branch of ADEQ, at the above address and telephone number or by email at [Water-Draft-Permit-Comment@adeq.state.ar.us](mailto:Water-Draft-Permit-Comment@adeq.state.ar.us).

*Publish on July 8, 2015 in Newton County Times*

**From:** [C H Hog Farms, Inc.](#)  
**To:** [Water Permit Application](#)  
**Cc:** [Bailey, John](#)  
**Subject:** Fw: Major Modification Request - C & H Hog Farms Pond Liners & Cover  
**Date:** Tuesday, May 19, 2015 10:31:10 AM  
**Attachments:** [Signed 5-7-15 Letter to ADEQ re Major Modification - Pond Liners and Cover.zip](#)  
[Signed NOI 5-7-15.zip](#)  
[Signed NPDES Permit Application Form 1 - C & H Hog Farms - Pond Liner.zip](#)  
[Signed Disclosure Statement 5-7-15.zip](#)  
[Stamped Design Plans for Liners & Cover.zip](#)

---

Attached are the drawings associated with this modification. We included these in the original email, but it appears the file was somehow dropped possibly due to the size/number of attachments. If you do not receive it with this transmission, please do not hesitate to let us know.

Thank you,  
Jason Henson

----- Forwarded Message -----

**From:** "C H Hog Farms, Inc." <chhogfarmsinc@yahoo.com>  
**To:** "water.permit.application@adeq.state.ar.us" <water.permit.application@adeq.state.ar.us>  
**Cc:** John Bailey <bailey@adeq.state.ar.us>  
**Sent:** Thursday, May 7, 2015 1:07 PM  
**Subject:** Major Modification Request - C & H Hog Farms Pond Liners & Cover

Please see the attached letter outlining our request.

Thank you,  
Jason Henson



Jason Henson  
C & H Hog Farms, Inc.  
HC 72 Box 10  
Mount Judea, AR 72655

May 7, 2015

**Re: Major Modification Request – Waste Storage Pond Liners and Cover  
AFIN: 51-00164, Permit No.: ARG590001**

Mr. John Bailey  
Permit Branch Manager  
Water Division  
Arkansas Department of Environmental Quality  
5301 Northshore Drive  
North Little Rock, AR 72118-5317

Dear Mr. Bailey:

C & H Hog Farms, Inc. is seeking the Department's approval of a major modification request to install pond liners in Waste Storage Ponds 1 and 2. A methane flare system and cover will be installed over Waste Storage Pond 1. This is the only revision we are seeking at this time.

Enclosed are the Notice of Intent (NOI), ADEQ Form 1, Disclosure Statement, and Design plans.

Please do not hesitate to contact me if you have any questions or concerns regarding this request.

Respectfully,

*Jason Henson*  
Jason Henson  
C & H Hog Farms, Inc.

Enclosures

**NPDES Notice of Intent (NOI)**  
**Concentrated Animal Feeding Operations(CAFO)**  
**ARG590000**

<b>I. GENERAL INFORMATION</b>		
A. TYPE OF BUSINESS	B. CONTACT INFORMATION	C. FACILITY OPERATION STATUS
Concentrated Animal Feeding Operation	Owner/or Operator Name <u>Jason Henson</u>  Address (No-POBOX) <u>HC 72 Box 10</u>  Telephone: <u>870-688-1318</u>  Email: <u>jasonh_1995@yahoo.com</u>  City <u>Mount Judea</u> State: <u>AR</u> Zip Code <u>72655</u>	<input checked="" type="checkbox"/> 1. Existing Facility  <input type="checkbox"/> 2. Proposed Facility
<b>D. FACILITY INFORMATION</b> Name: <u>C &amp; H Hog Farms</u> Telephone: <u>870-688-1318</u>  Address: <u>HC 72 Box 10</u>  City: <u>Mount Judea</u> State: <u>AR</u> Zip Code: <u>72655</u>  County: <u>Newton</u> Latitude: <u>35.55' 13.6"</u> Longitude: <u>-93.4' 51.0"</u>  If contract operation: Name of Integrator: _____  Address of Integrator: _____		
<b>II CONCENTRATED ANIMAL FEEDING OPERATION CHARACTERISTICS</b>		
A. TYPE AND NUMBER OF ANIMALS	B. Manure, Litter, and/or Wastewater Production and Use	
2. ANIMALS	1. How much manure, litter, and wastewater is generated annually by the facility? .....tons <u>2,090,081</u> gallons  2. If land applied how many acres of land under the control of the applicant are available for applying the CAFOs manure/litter/wastewater? <u>630.7</u> acres  3. How many tons of manure or litter, or gallons of wastewater produced by the CAFO will be transferred annually to other persons? <u>0</u> tons/gallons (circle one)	
1. TYPE	NO. IN OPEN CONFINEMENT	NO. HOUSED UNDER ROOF
<input type="checkbox"/> Mature Dairy Cows		
<input type="checkbox"/> Dairy Heifers		
<input type="checkbox"/> Veal Calves		
<input type="checkbox"/> Cattle (not dairy or veal calves)		
<input checked="" type="checkbox"/> Swine (55 lbs. or over)		2,503
<input checked="" type="checkbox"/> Swine (under 55 lbs.)		4,000
<input type="checkbox"/> Horses		

<input type="checkbox"/> Sheep or Lambs			
<input type="checkbox"/> Turkeys			
<input type="checkbox"/> Chickens (Broilers)			
<input type="checkbox"/> Chickens (Layers)			
<input type="checkbox"/> Ducks			
<input type="checkbox"/> Other Specify.....			
3. TOTAL ANIMALS		6,503	

C.  TOPOGRAPHIC MAP

D. TYPE OF CONTAINMENT, STORAGE AND CAPACITY

1. Type of Containment	Total Capacity (in gallons)	
<input type="checkbox"/> Lagoon		
<input checked="" type="checkbox"/> Holding Pond	2,735,922	
<input type="checkbox"/> Evaporation Pond		
<input checked="" type="checkbox"/> Other: Specify <u>Shallow Pits</u>	759,542	

2. Report the total number of acres contributing drainage: 0 acres

3. Type of Storage	Total Number of Days	Total Capacity (gallons/tons)	
<input type="checkbox"/> Anaerobic Lagoon			
<input type="checkbox"/> Storage Lagoon			
<input type="checkbox"/> Evaporation Pond			
<input type="checkbox"/> Aboveground Storage Tanks			
<input type="checkbox"/> Belowground Storage Tanks			
<input type="checkbox"/> Roofed Storage Shed			
<input type="checkbox"/> Concrete Pad			
<input type="checkbox"/> Impervious Soil Pad			
<input type="checkbox"/> Other: Specify _____			



E. NUTRIENT MANAGEMENT PLAN

**Note: A permit application is not complete until a nutrient management plan (NMP) is submitted with NOI.**

1. Please indicate whether a nutrient management plan has been included with this permit application.  Yes No (STOP)
2. Is a nutrient management plan being implemented for the facility?  Yes No
3. The date of the last review or revision of the nutrient management plan. Date: May 7, 2015
4. If not land applying, describe alternative use(s) of manure, litter, and or wastewater:

\_\_\_\_\_

\_\_\_\_\_

F. LAND APPLICATION BEST MANAGEMENT PRACTICES

Please check any of the following best management practices that are being implemented at the facility to control runoff and protect water quality:

- Buffers  Setbacks  Conservation tillage  Constructed wetlands  Infiltration field  Grass filter  Terrace

III. CERTIFICATION

*I certify under penalty of law that I have personally examined and am familiar with the information submitted in this application and all attachments and that, based on my inquiry of those individuals immediately responsible for obtaining the information, I believe that the information is true accurate and complete. I am aware that there are significant penalties for submitting false information, including the possibility of fine and imprisonment.*

A. Name and Official Title (*print or type*)  
Jason Henson, President

B. Phone No. (870 ) 688-1318

C. Signature

*Jason Henson*

D. Date Signed 5/7/15

**Arkansas Department of Environmental Quality**  
**NPDES PERMIT APPLICATION**  
**FORM 1**

**INSTRUCTIONS:**

1. This form should be **typed or printed in ink**. If insufficient space is available to address any item please continue on an attached sheet of paper.
2. Please complete the following Section(s). If a Section is not required, please check the Not Applicable (N/A) box at the top of the Section.

Sections	A	B	C	D	E	F	G	H	I
POTW	X	X	X	X					X
Industrial User	X	X	X	X	X	X	X		X
Construction Permit Only	X	X	*	X				X	X
Modification	X	X	X	X	X	*	*	X	X
All Other Applicants	X	X	X	X	X				X

\* As necessary

3. If you need help on SIC or NAICS go to [www.osha.gov/oshstats/sicser.html](http://www.osha.gov/oshstats/sicser.html)
4. If you have any questions about this form you may call NPDES Section at 501-682-0622 or go to [www.adeq.state.ar.us/water](http://www.adeq.state.ar.us/water). You may also contact :

Department	Information in Regard to	Telephone #
Arkansas Department of Health	Water Supply	501-661-2623

5. The following EPA Forms in addition to Form 1 is required for processing your application:
  - Form 2A** - Municipal Dischargers
  - Form 2B** - Concentrated Animal Feeding Operations
  - Form 2C** - Existing Manufacturing, Commercial, Mining, and Silvicultural Operations
  - Form 2D** - New Sources and New Dischargers Application for Permit to Discharge Process Wastewater
  - Form 2E** - Facilities Which Do Not Discharge Process Wastewater (i.e. Domestic, Non contact cooling water)
  - Form 2F** - Application for Permit to Discharge Storm Water Discharges Associated With Industrial Activity

6. Where to Submit

Return the completed form by mail to:

Arkansas Department of Environmental Quality  
 Permits Branch, Water Division  
 5301 Northshore Drive  
 North Little Rock, AR 72118

Or by email to:

[Water.Permit.Application@adeq.state.ar.us](mailto:Water.Permit.Application@adeq.state.ar.us)



## SECTION I: SIGNATORY REQUIREMENTS

### Cognizant Official (Duly Authorized Representative)

40 CFR 122.22(b) states that all reports required by the permit, or other information requested by the Director, shall be signed by the applicant (or person authorized by the applicant) or by a duly authorized representative of that person. A person is duly authorized representative only if:

- (1) the authorization is made in writing by the applicant (or person authorized by the applicant);
- (2) the authorization specifies either an individual or a position having responsibility for the overall operation of the regulated facility or activity responsibility, or an individual or position having overall responsibility for environmental matters for the company.

The applicant hereby designates the following person as a Cognizant Official, or duly authorized representative, for signing reports, etc., including Discharge Monitoring Reports (DMR) required by the permit, and other information requested by the Director:

Signature of Cognizant Official: Philip Campbell Date: 5/7/15  
Printed name of Cognizant Official: Philip Campbell  
Official title of Cognizant Official: Secretary Telephone Number: 870-715-0754

### Responsible Official

The information contained in this form must be certified by a responsible official as defined in the "signatory requirements for permit applications" (40 CFR 122.22).

Responsible official is defined as follows:

**Corporation**, a principal officer of at least the level of vice president

**Partnership**, a general partner

**Sole proprietorship**: the proprietor

**Municipal, state, federal, or other public facility**: principal executive officer, or ranking elected official.

JH (Initial) "I certify that the cognizant official designated above is qualified to act as a duly authorized representative under the provisions of 40 CFR 122.22(b)." NOTE: If no duly authorized representative is designated in this section, the Department considers the applicant to be the responsible official for the facility and only reports, etc., signed by the applicant will be accepted by the Department.

JH (Initial) "I certify that, if this facility is a corporation, it is registered with the Secretary of State in Arkansas. Please provide the full name of the corporation if different than that listed in Section A above."

"I certify under penalty of law that this document and all attachments were prepared under my direction or supervision in accordance with a system designed to assure that qualified personnel properly gather and evaluate the information submitted. Based on my inquiry of the person or persons who manage the system, or those persons directly responsible for gathering the information, the information submitted is, to the best of my knowledge and belief, true, accurate, and complete. I am aware that there are significant penalties for submitting false information including the possibility of fine and imprisonment for knowing violations. I further certify under penalty of law that all analyses reported as less than detectable in this application or attachments thereto were performed using the EPA approved test method having the lowest detection limit for the substance tested."

Signature of Responsible Official: Jason Henson Date: 5/7/15  
Printed name of Responsible Official: Jason Henson  
Official title of Responsible Official: President Telephone Number: 870-688-1318



# C & H HOG FARMS GESTATION-FARROWING FARM

## ENGINEERING PLAN SHEETS

SECTION 26, T 15 N, R 20 W  
NEWTON COUNTY, ARKANSAS

DATE: APRIL 15, 2015

### SHEET INDEX

- ADDENDUM 1 – WASTE STORAGE POND HDPE LINER DETAILS
- ADDENDUM 2 – WASTE STORAGE POND 1 HDPE COVER DETAILS
- ADDENDUM 3 – WASTE STORAGE POND 1 BALLAST PIPE DETAILS
- ADDENDUM 4 – MISCELLANEOUS DETAILS
- ADDENDUM 5 – MISCELLANEOUS DETAILS 2
- ADDENDUM 6 – WASTE STORAGE POND 1 BASELINER PANEL LAYOUT
- ADDENDUM 7 – WASTE STORAGE POND 2 BASELINER PANEL LAYOUT
- ADDENDUM 8 – BASELINER DETAILS
- ADDENDUM 9 – UNDER LINER VENT DETAILS

GENERAL NOTES



No.	Revision/Issue	Date

**DeHaan, Grabs  
& Associates, LLC**  
Consulting Engineers  
PO Box 522, Mandan, ND 58554  
(701) 663-1116, FAX: (701) 667-1356  
www.dgaengineering.com

**C & H HOG FARMS  
GESTATION-FARROWING FARM**

SECTION 26, T 15 N, R 20 W  
NEWTON COUNTY, AR

**COVER SHEET**

DATE: APRIL 15, 2015	SHEET:  <b>COVER</b>
SCALE: NONE	
DRAWN BY: NAP	
CHECKED BY: DLD	



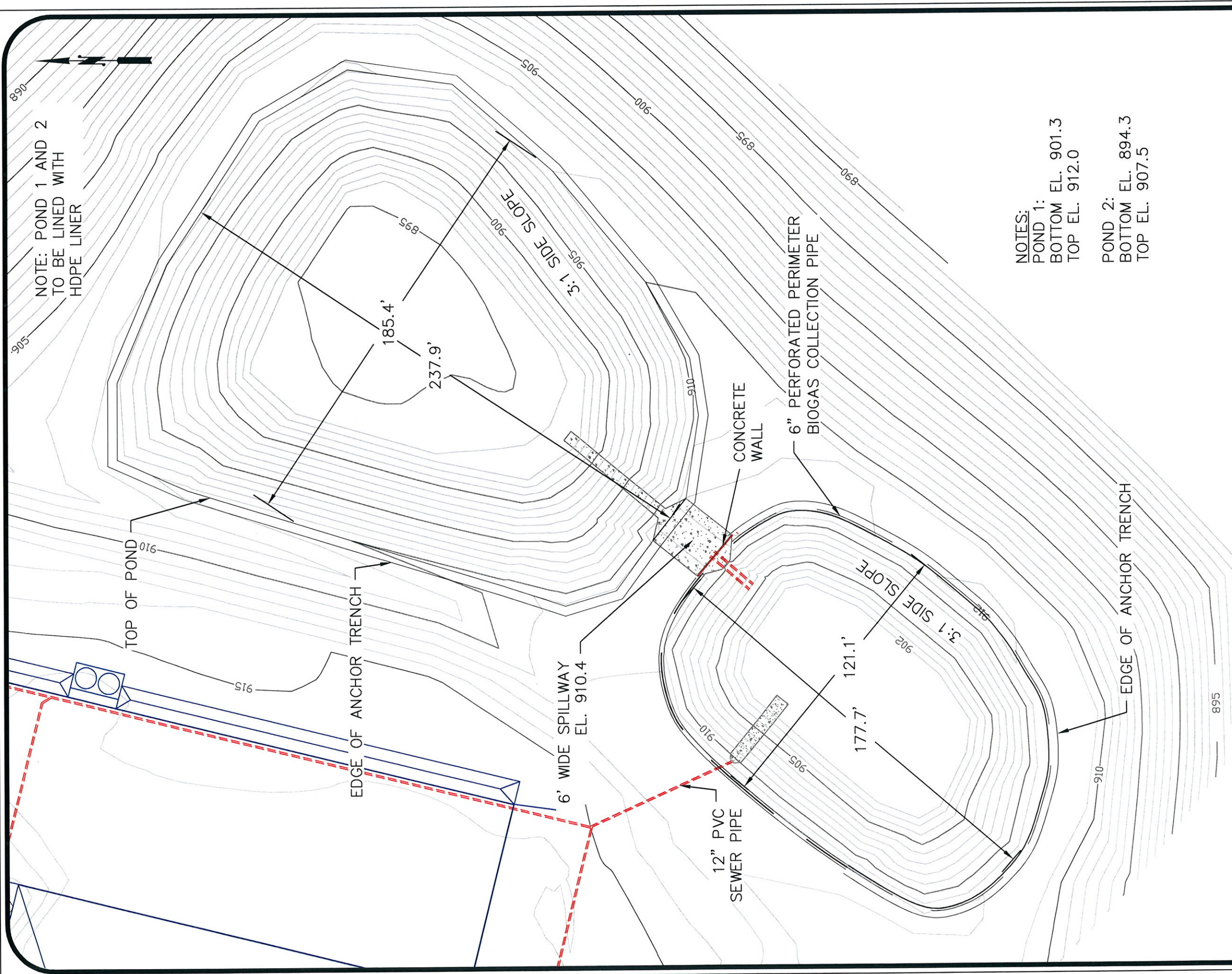

NOTES:  
 POND 1:  
 BOTTOM EL. 901.3  
 TOP EL. 912.0  
 POND 2:  
 BOTTOM EL. 894.3  
 TOP EL. 907.5

GENERAL NOTES

LEGEND

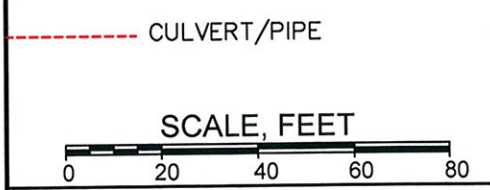

No.	Revision/Issue	Date

**DeHaan, Grabs & Associates, LLC**  
 Consulting Engineers  
 PO Box 522, Mandan, ND 58554  
 (701) 663-1116, FAX: (701) 667-1356  
 www.dgaengineering.com

**C & H HOG FARMS**  
 GESTATION-FARROWING FARM

SECTION 26, T 15 N, R 20 W  
 NEWTON COUNTY, AR

**WASTE STORAGE POND**  
 HDPE LINER DETAILS

DATE: APR 7, 2015	SHEET:  ADDENDUM 1
SCALE: 1" = 40'	
DRAWN BY: NAP	
CHECKED BY: DLD	



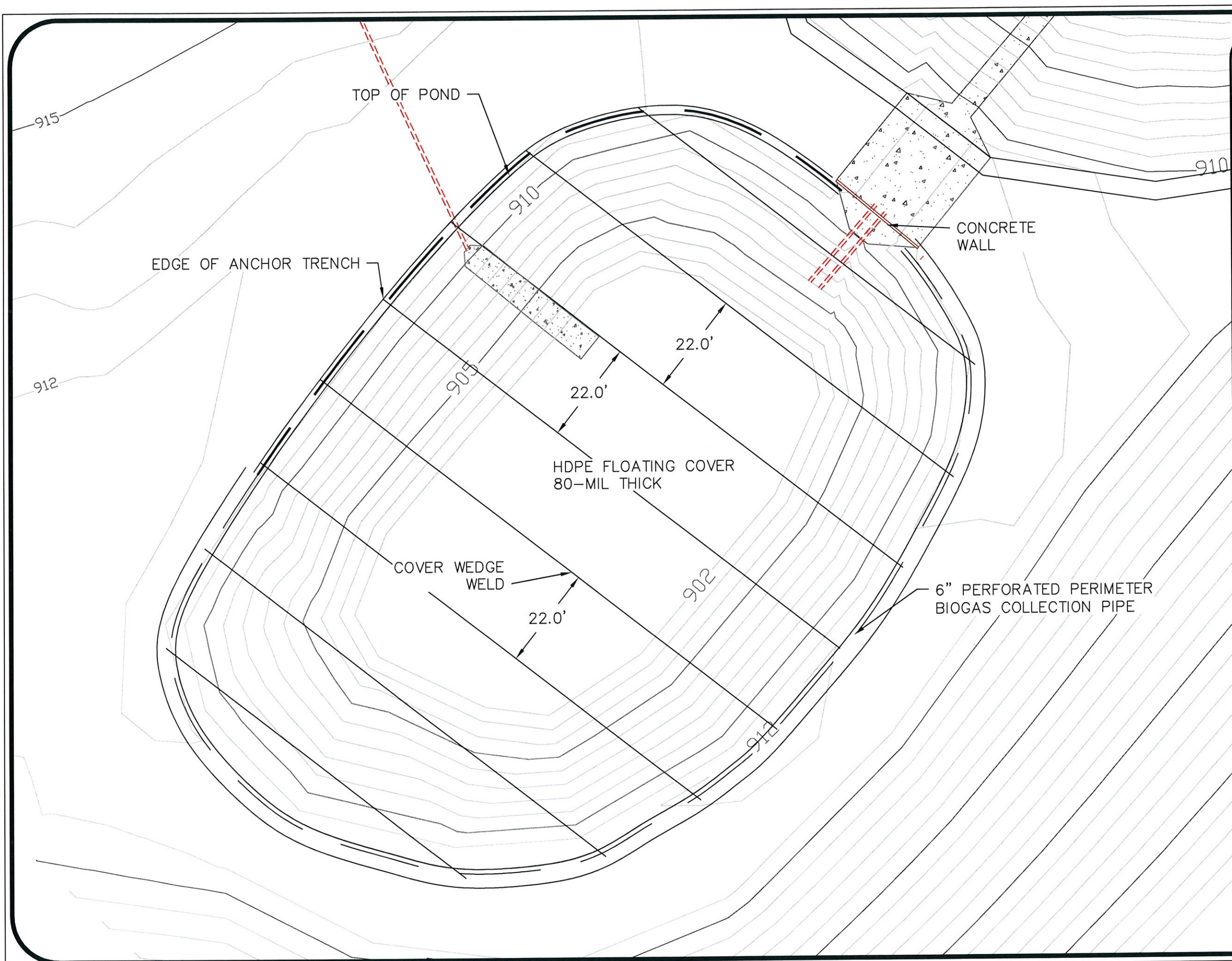

GENERAL NOTES

LEGEND

--- CULVERT/PIPE

SCALE, FEET

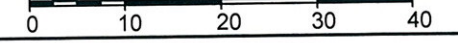

No.	Revision/Issue	Date

**DeHaan, Grabs & Associates, LLC**  
 Consulting Engineers  
 PO Box 522, Mandan, ND 58554  
 (701) 663-1116, FAX: (701) 667-1356  
 www.dgaengineering.com

**C & H HOG FARMS**  
 GESTATION-FARROWING FARM

SECTION 26, T 15 N, R 20 W  
 NEWTON COUNTY, AR

**WASTE STORAGE POND 1**  
**HDPE COVER DETAILS**

DATE: APR 7, 2015	SHEET:  ADDENDUM 2
SCALE: 1" = 20'	
DRAWN BY: NAP	
CHECKED BY: DLD	



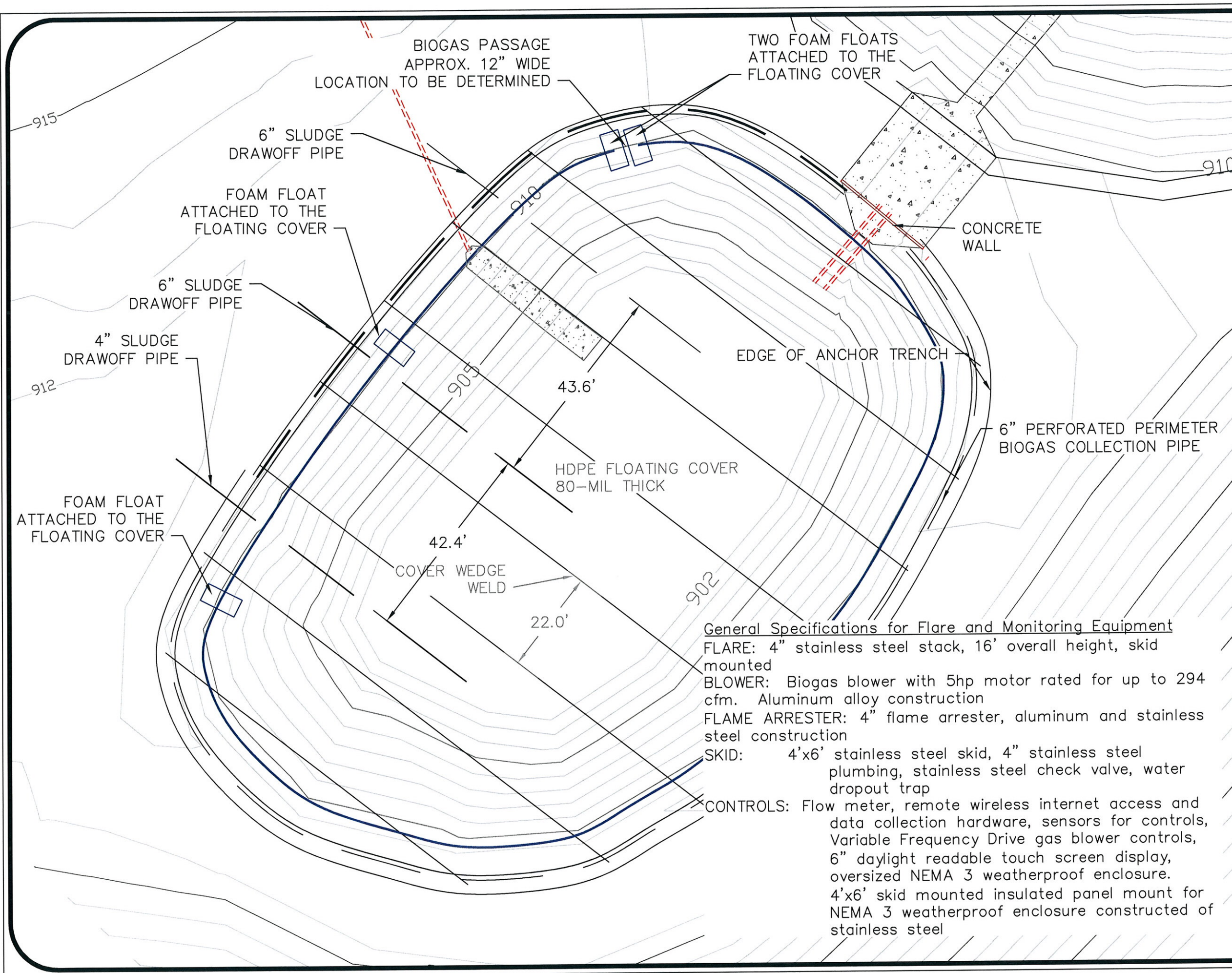

**General Specifications for Flare and Monitoring Equipment**  
**FLARE:** 4" stainless steel stack, 16' overall height, skid mounted  
**BLOWER:** Biogas blower with 5hp motor rated for up to 294 cfm. Aluminum alloy construction  
**FLAME ARRESTER:** 4" flame arrester, aluminum and stainless steel construction  
**SKID:** 4'x6' stainless steel skid, 4" stainless steel plumbing, stainless steel check valve, water dropout trap  
**CONTROLS:** Flow meter, remote wireless internet access and data collection hardware, sensors for controls, Variable Frequency Drive gas blower controls, 6" daylight readable touch screen display, oversized NEMA 3 weatherproof enclosure. 4'x6' skid mounted insulated panel mount for NEMA 3 weatherproof enclosure constructed of stainless steel

GENERAL NOTES

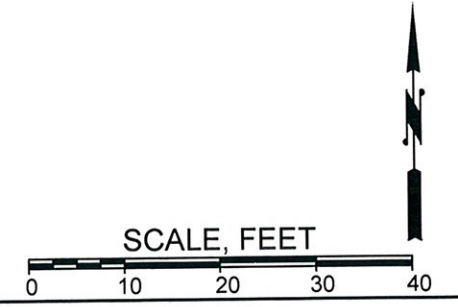

No.	Revision/Issue	Date

**DeHaan, Grabs & Associates, LLC**  
 Consulting Engineers  
 PO Box 522, Mandan, ND 58554  
 (701) 663-1116, FAX: (701) 667-1356  
 www.dgaengineering.com

**C & H HOG FARMS**  
 GESTATION-FARROWING FARM  
 SECTION 26, T 15 N, R 20 W  
 NEWTON COUNTY, AR  
**WASTE STORAGE POND 1**  
**BALLAST PIPE DETAILS**

DATE: APR 7, 2015	SHEET:  ADDENDUM 3
SCALE: 1" = 20'	
DRAWN BY: NAP	
CHECKED BY: DLD	



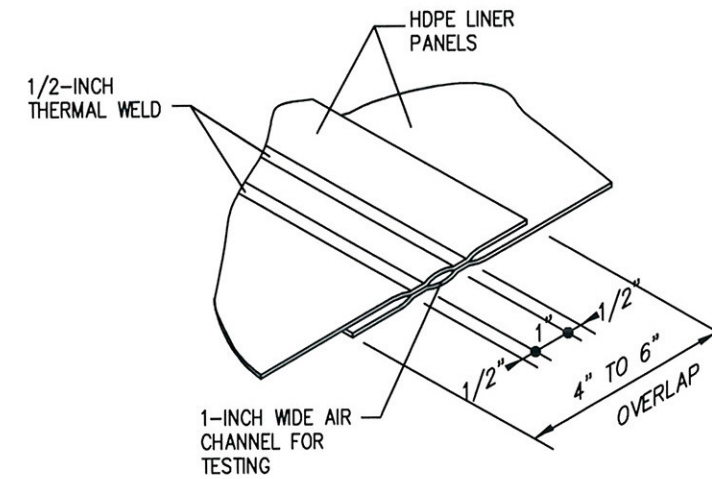
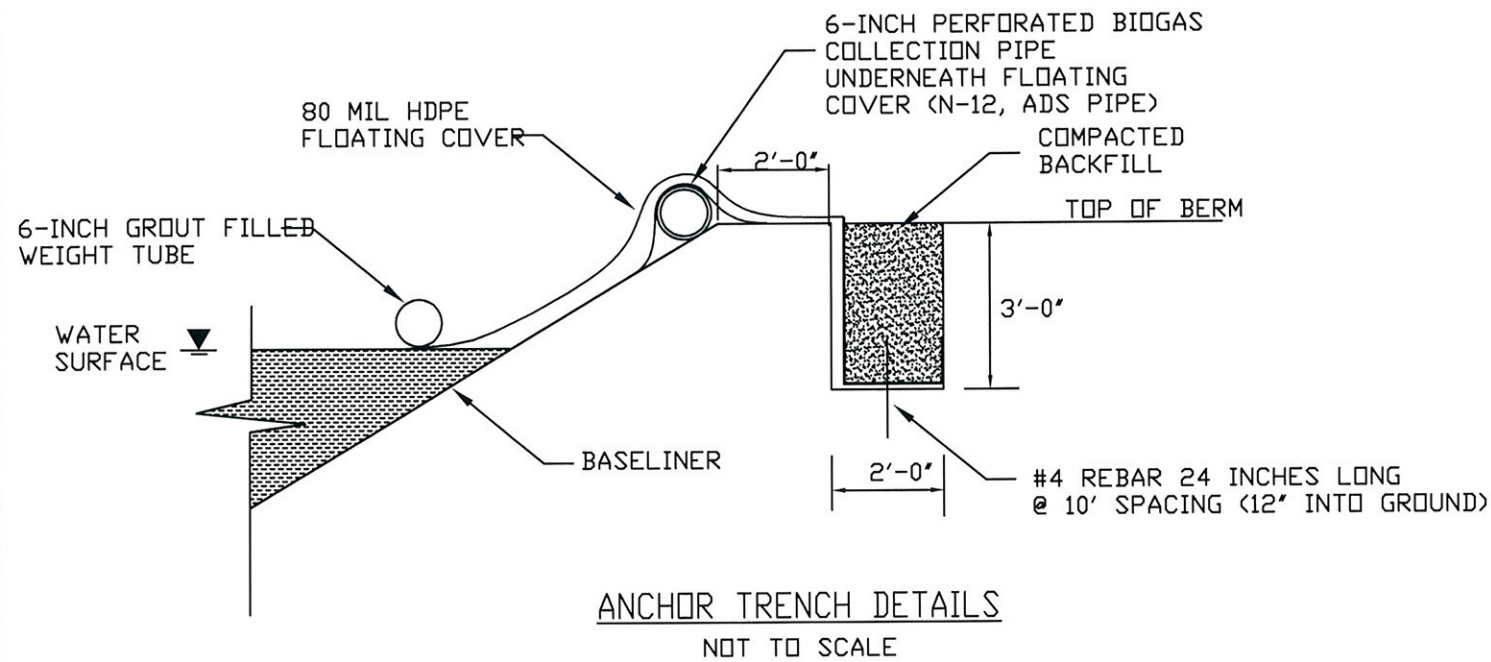

SEAM CROSS SECTION WIDE AIR CHANNEL WELDER

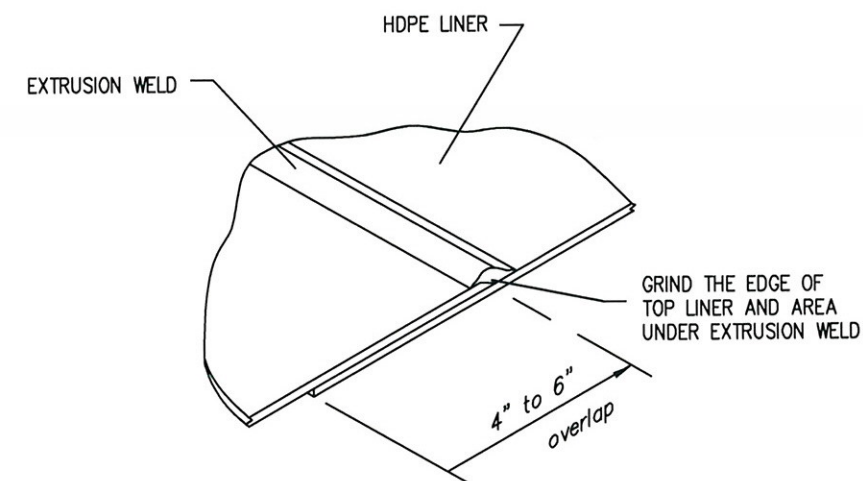
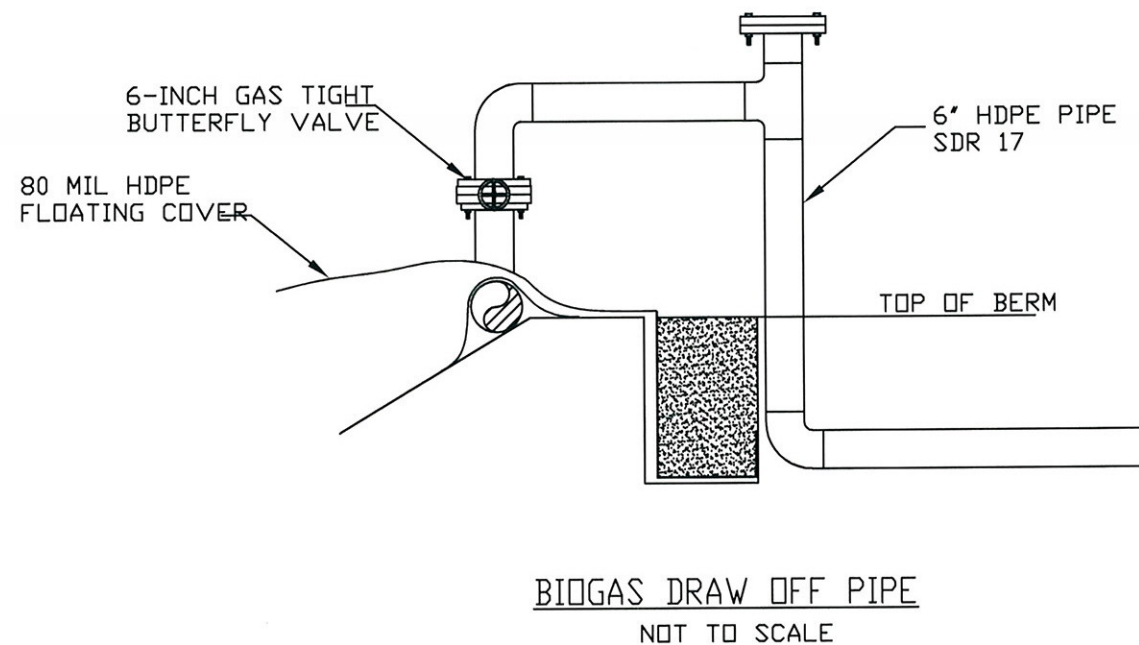

SEAM CROSS SECTION FOR THE EXTRUSION WELD

GENERAL NOTES



No.	Revision/Issue	Date

**DeHaan, Grabs & Associates, LLC**  
 Consulting Engineers  
 PO Box 522, Mandan, ND 58554  
 (701) 663-1116, FAX: (701) 667-1356  
 www.dgaengineering.com

**C & H HOG FARMS**  
 GESTATION-FARROWING FARM

SECTION 26, T 15 N, R 20 W  
 NEWTON COUNTY, AR

MISCELLANEOUS  
 DETAILS

DATE: APR 7, 2015	SHEET:  ADDENDUM 4
SCALE: NOT TO SCALE	
DRAWN BY: NAP	
CHECKED BY: DLD	



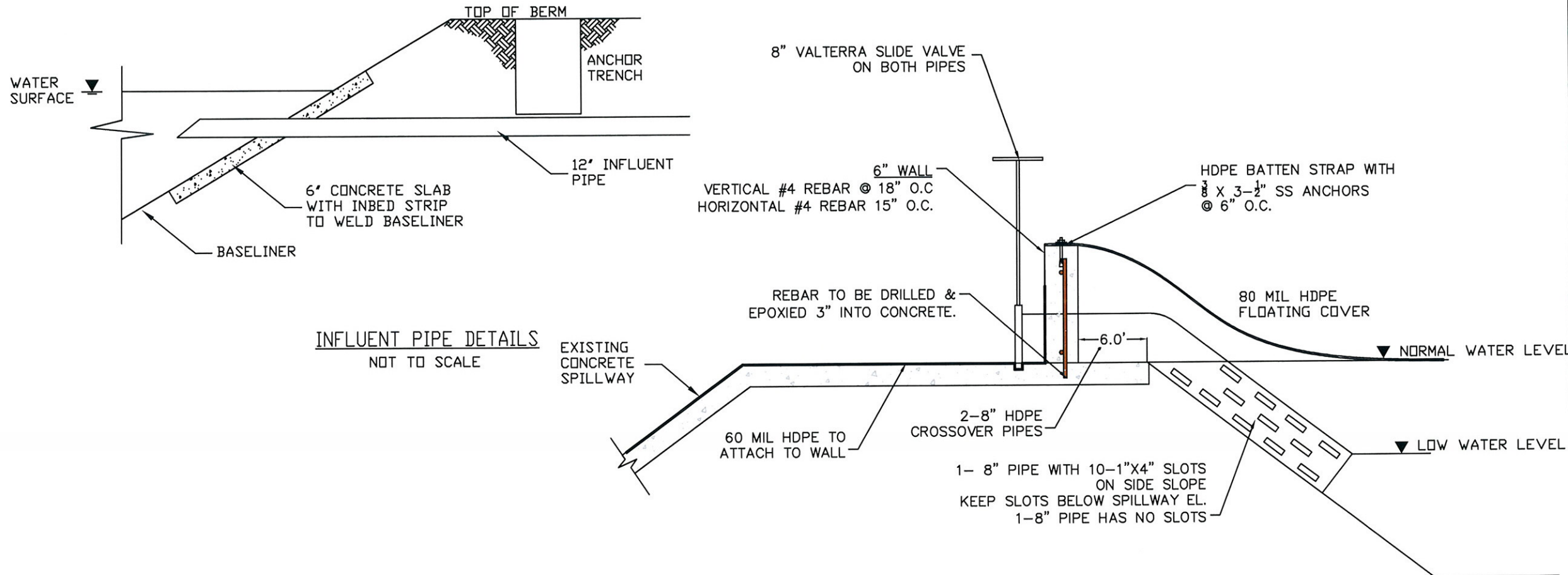

INFLUENT PIPE DETAILS  
NOT TO SCALE

EXISTING  
CONCRETE  
SPILLWAY

FLOATING COVER ANCHORING DETAILS NEAR SPILLWAY  
NOT TO SCALE

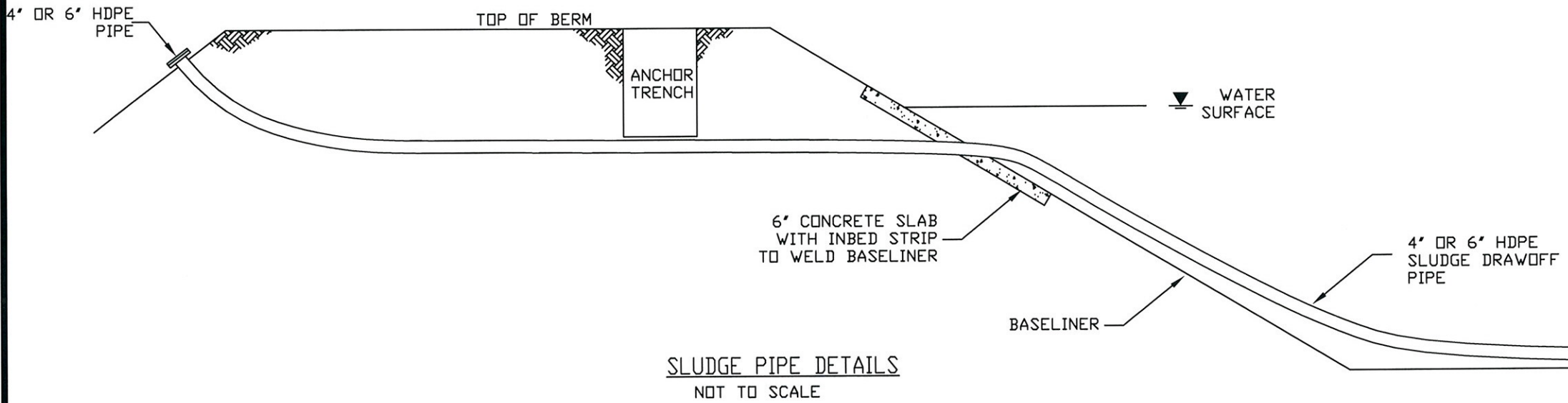

SLUDGE PIPE DETAILS  
NOT TO SCALE

GENERAL NOTES



No.	Revision/Issue	Date

**DeHaan, Grabs & Associates, LLC**  
 Consulting Engineers  
 PO Box 522, Mandan, ND 58554  
 (701) 663-1116, FAX: (701) 667-1356  
 www.dgaengineering.com

**C & H HOG FARMS**  
 GESTATION-FARROWING FARM  
 SECTION 26, T 15 N, R 20 W  
 NEWTON COUNTY, AR  
**MISCELLANEOUS  
 DETAILS 2**



DATE: APR 7, 2015	SHEET:  ADDENDUM 5
SCALE: NOT TO SCALE	
DRAWN BY: NAP	
CHECKED BY: DLD	

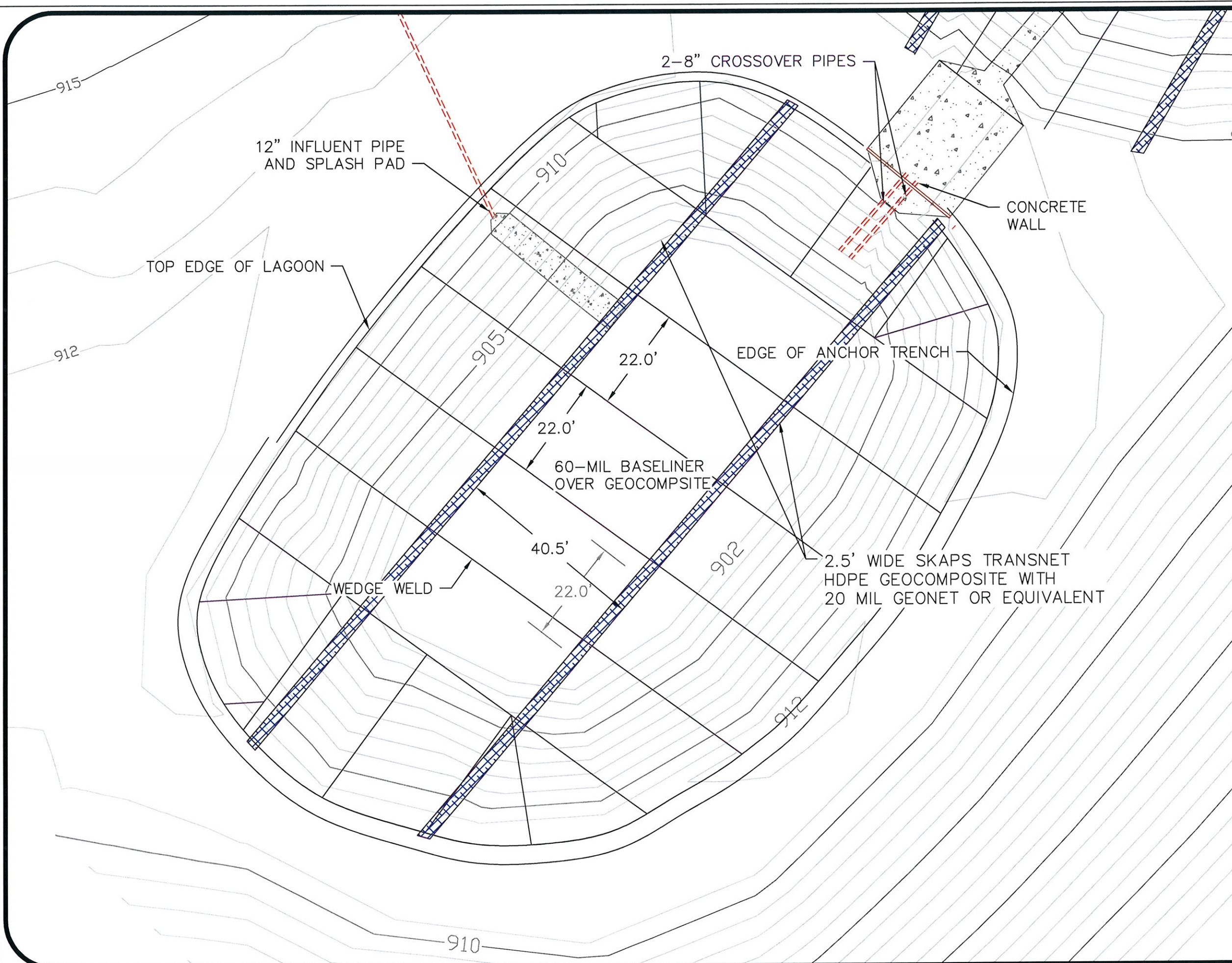



GENERAL NOTES

LEGEND

-  GEOMAT VENT
-  CULVERT/PIPE

SCALE, FEET

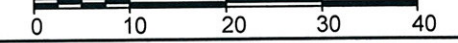

No.	Revision/Issue	Date

**DeHaan, Grabs & Associates, LLC**  
 Consulting Engineers  
 PO Box 522, Mandan, ND 58554  
 (701) 663-1116, FAX: (701) 667-1356  
 www.dgaengineering.com

**C & H HOG FARMS**  
 GESTATION-FARROWING FARM

SECTION 26, T 15 N, R 20 W  
 NEWTON COUNTY, AR

**WASTE STORAGE POND 1  
 BASELINER PANEL LAYOUT**

DATE: APR 7, 2015	SHEET:  ADDENDUM 6
SCALE: 1" = 20'	
DRAWN BY: NAP	
CHECKED BY: DLD	



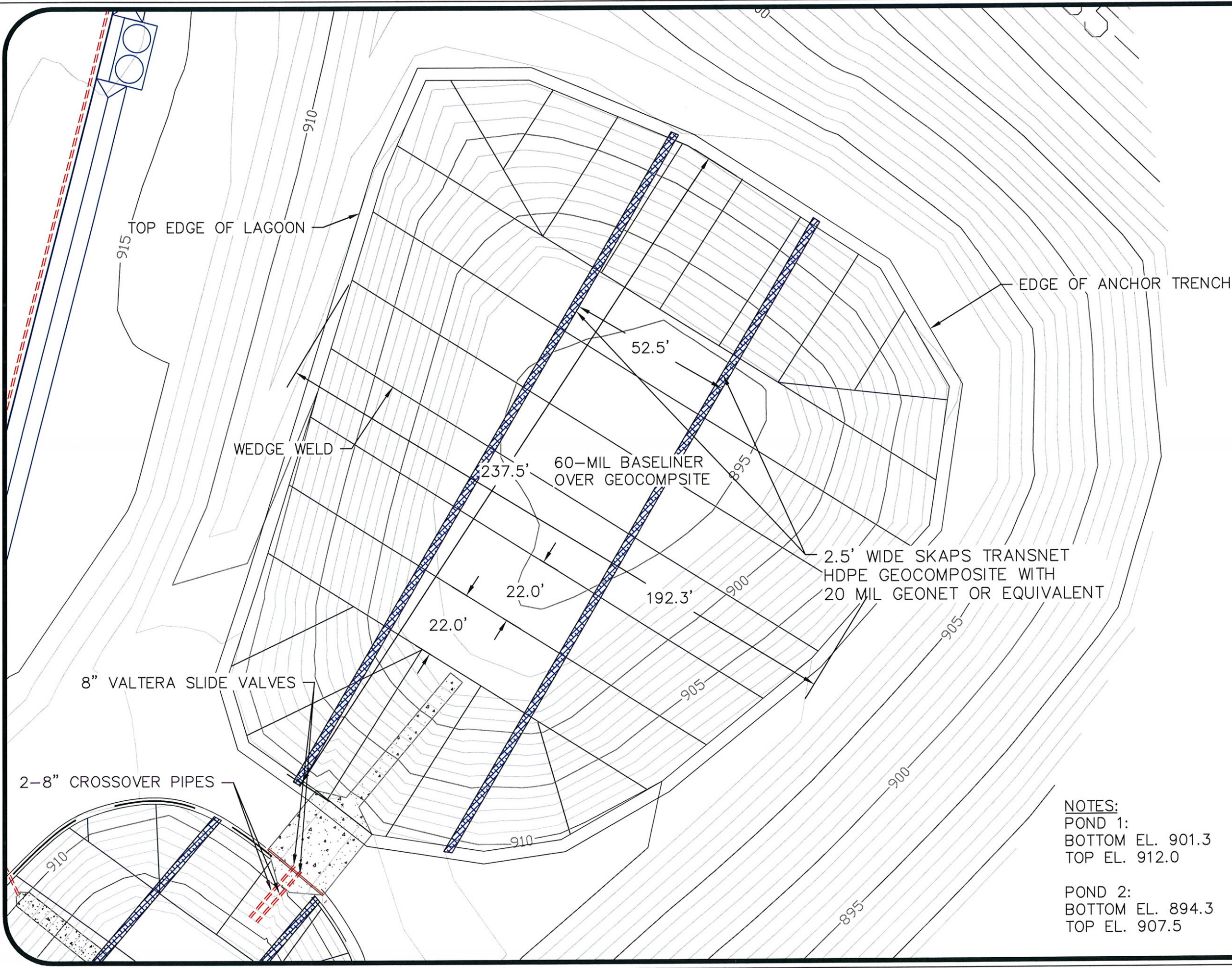

GENERAL NOTES

LEGEND

- GEOMAT VENT
- CULVERT/PIPE

SCALE, FEET

STATE OF  
  
 LICENSED  
 PROFESSIONAL  
 ENGINEER  
 No. 15552  
 4/15/15  
 NATHAN A. PESTA

No.	Revision/Issue	Date

**DeHaan, Grabs & Associates, LLC**  
 Consulting Engineers  
 PO Box 522, Mandan, ND 58554  
 (701) 663-1116, FAX: (701) 667-1356  
 www.dgaengineering.com

**C & H HOG FARMS**  
 GESTATION-FARROWING FARM

SECTION 26, T 15 N, R 20 W  
 NEWTON COUNTY, AR

**WASTE STORAGE POND 2  
 BASELINER PANEL LAYOUT**

NOTES:  
 POND 1:  
 BOTTOM EL. 901.3  
 TOP EL. 912.0

POND 2:  
 BOTTOM EL. 894.3  
 TOP EL. 907.5

DATE: APR 7, 2015	SHEET:
SCALE: 1" = 30'	ADDENDUM 7
DRAWN BY: NAP	
CHECKED BY: DLD	



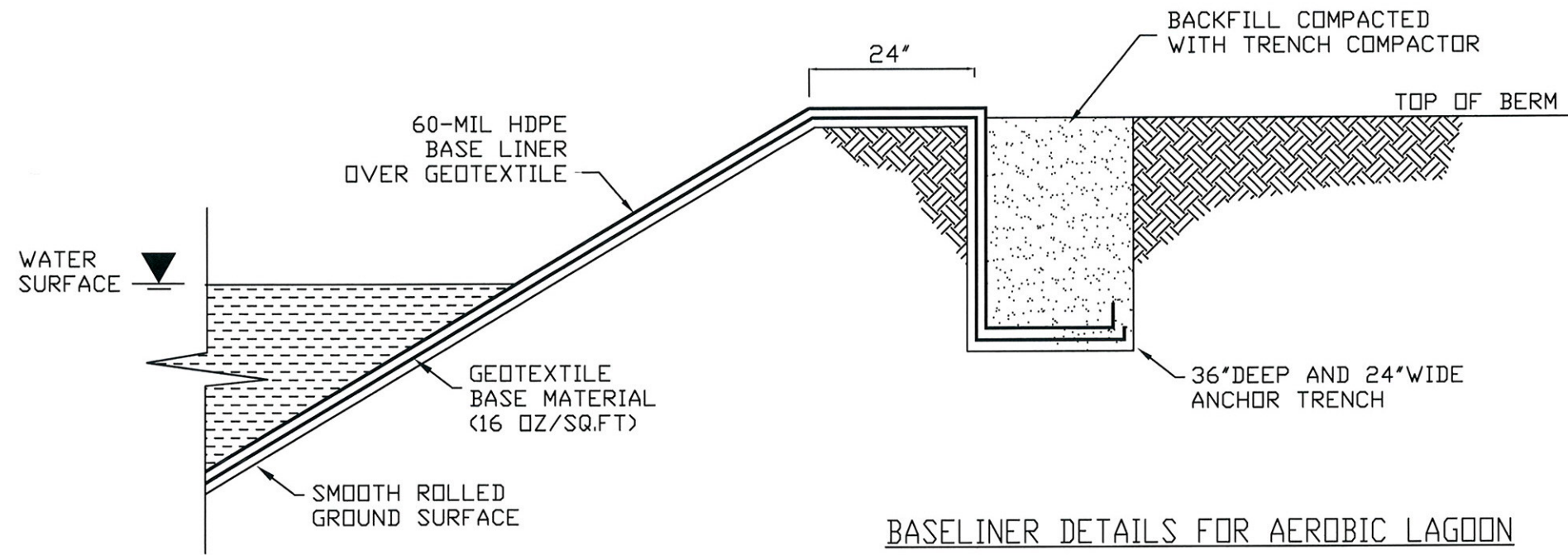

BASELINER DETAILS FOR AEROBIC LAGOON

NOT TO SCALE

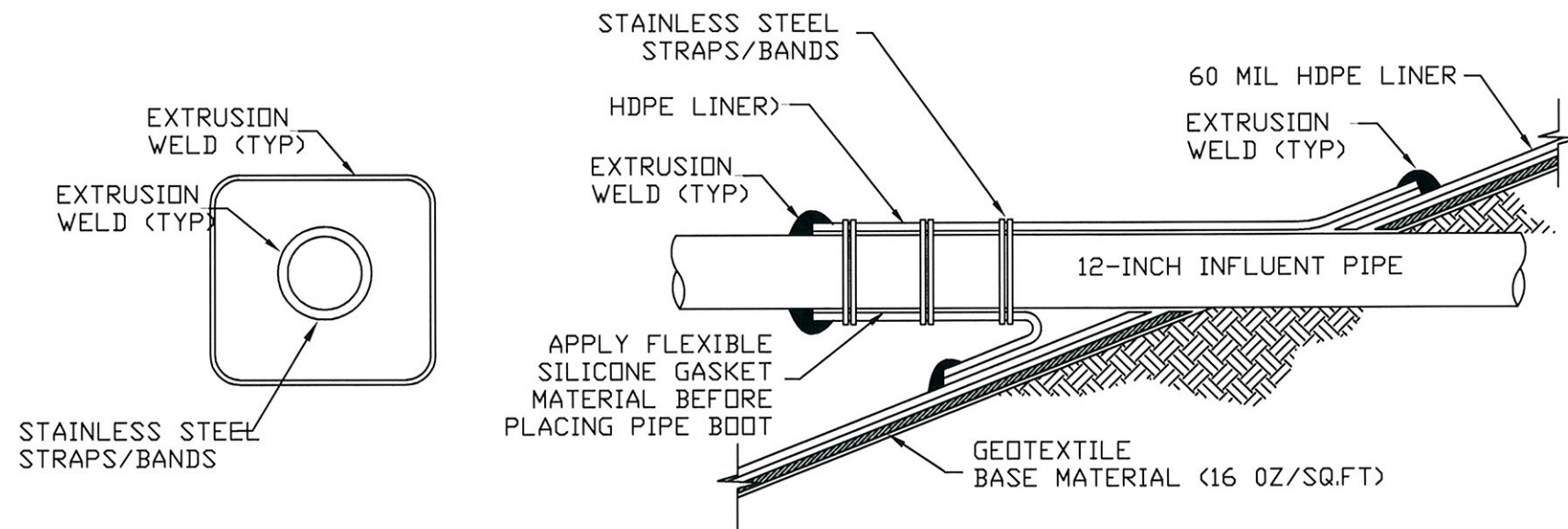

PIPE PENETRATION DETAIL

NOT TO SCALE

GENERAL NOTES

LEGEND



No.	Revision/Issue	Date

**DeHaan, Grabs & Associates, LLC**  
 Consulting Engineers  
 PO Box 522, Mandan, ND 58554  
 (701) 663-1116, FAX: (701) 667-1356  
 www.dgaengineering.com

**C & H HOG FARMS**  
 GESTATION-FARROWING FARM

SECTION 26, T 16 N, R 20 W  
 NEWTON COUNTY, AR

BASELINER DETAILS

DATE: APR 7, 2015	SHEET:  ADDENDUM 8
SCALE: NOT TO SCALE	
DRAWN BY: NAP	
CHECKED BY: DLD	



# INSTRUCTIONS FOR DISCLOSURE STATEMENT

Arkansas Code Annotated Section 8-1-106 requires that all applicants for the issuance, or transfer of any permit, license, certification or operational authority issued by the Arkansas Department of Environmental Quality (ADEQ) file a disclosure statement with their applications. The filing of a disclosure statement is mandatory. No application can be considered complete without one.

Disclosure statement means a written statement by the applicant that contains:

- The full name and business address of the applicant and all affiliated persons;
- The full name and business address of any legal entity in which the applicant holds a debt or equity interest of at least five percent (5%) or that is a parent company or subsidiary of the applicant, and a description of the ongoing organizational relationships as they may impact operations within the state;
- A description of the experience and credentials of the applicant, including any past or present permits, licenses, certifications, or operational authorizations relating to environmental regulation;
- A listing and explanation of any civil or criminal legal actions by government agencies involving environmental protection laws or regulations against the applicant and affiliated persons in the ten (10) years immediately preceding the filing of the application, including administrative enforcement actions resulting in the imposition of sanctions, permit or license revocations or denials issued by any state or federal authority, actions that have resulted in a finding or a settlement of a violation, and actions that are pending;
- A listing of any federal environmental agency and any other environmental agency outside this state that has or has had regulatory responsibility over the applicant; and
- Any other information the Director of the Arkansas Department of Environmental Quality may require that relates to the competency, reliability, or responsibility of the applicant and affiliated persons.

## Exemptions:

The following persons or entities are not required to file a disclosure statement:

- Governmental entities, consisting only of subdivisions or agencies of the federal government, agencies of the state government, counties, municipalities, or duly authorized regional solid waste authorities as defined by § 8-6-702. (This exemption shall not extend to improvement districts or any other subdivision of government which is not specifically instituted by an act of the General Assembly.)
- Applicants for a general permit to be issued by the department pursuant to its authority to implement the National Pollutant Discharge Elimination System for storm water discharge.
- If the applicant is a publicly held company required to file periodic reports under the Securities and Exchange Act of 1934 or a wholly owned subsidiary of a publicly held company, the applicant shall not be required to submit a disclosure statement, but shall submit the most recent annual and quarterly reports required by the Securities and Exchange Commission which provide information regarding legal proceedings in which the applicant has been involved. The applicant shall submit such other information as the director may require that relates to the competency, reliability, or responsibility of the applicant and affiliated persons.



## **Exemptions continued:**

The following permits, licenses, certifications, and operational authorizations are also exempt from submitting a disclosure statement:

- **Hazardous Waste Treatment, Storage, and Disposal Permit Modifications (Class 1, 2, and 3), as defined in Arkansas Pollution Control and Ecology Commission (APC&EC) Regulation 23;**
- **Phase 1 Consultants, as defined in APC&EC Regulation 32;**
- **Certifications for Operators of Commercial Hazardous Waste Facilities, as defined in APC&EC Regulation 23 § 264.16(f);**
- **Regulated Storage Tank Contractor or Individual License Renewals as defined in APC&EC Regulation 12;**
- **Certifications for Persons Operating and Maintaining Underground Storage Tank Systems which Contain Regulated Substances, as defined in APC&EC Regulation 12.701, *et. seq.*;**
- **Individual Homeowners seeking coverage under General Permit ARG5500000;**
- **Wastewater Operator Licenses, as defined in APC&EC Regulation 3;**
- **Water Permit Modifications for permits issued under the authority of the Arkansas Water and Air Pollution Control Act (Ark. Code Ann. §8-4-101, *et. seq.*);**
- **Solid Waste Permit Modifications for permits issued under APC&EC Regulation 22;**
- **Solid Waste Landfill Operator License Renewals, as defined in Regulation No. 27;**
- **Air Permit Modifications for permits issued under APC&EC Regulations 18, 19, and 26; and**
- **Asbestos Certification Renewals, as defined in Regulation 21.**

**Deliberate falsification or omission of relevant information from disclosure statements shall be grounds for civil or criminal enforcement action or administrative denial of a permit, license, certification, or operational authorization.**

# ARKANSAS DEPARTMENT OF ENVIRONMENTAL QUALITY DISCLOSURE STATEMENT

## Instructions for the Completion of this Document:

- A. Individuals, firms or other legal entities with no changes to an ADEQ Disclosure Statement, complete items 1 through 5 and 18.
- B. Individuals who never submitted an ADEQ Disclosure Statement, complete items 1 through 4, 6, 7, and 16 through 18.
- C. Firms or other legal entities who never submitted an ADEQ Disclosure Statement, complete 1 through 4, and 6 through 18.

If Not Submitting by ePortal, Mail Original to:

ADEQ

DISCLOSURE STATEMENT

[List Proper Division(s)]

5301 Northshore Drive

North Little Rock, AR 72118-5317

1. APPLICANT: (Full Name)

C & H Hog Farms, Inc.

2. MAILING ADDRESS (Number and Street, P.O.Box Or Rural Route) :

HC 72 Box 10

3. CITY, STATE, AND ZIPCODE:

Mount Judea, AR 72655

4a. Applicant Type:

Individual  Corporate or Other Entity

4b. Reason for Submission:

Permit  License  Certification  Operational Authority

New Application  Modification  Renewal Application (If no changes from previous disclosure statement, complete number 5 and 18.)

4c. Division:

Air  Water  Hazardous Waste  Regulated Storage Tank  Mining  Solid Waste

5. Declaration of No Changes:

The violation history, experience and credentials, involvement in current or pending environmental lawsuits, civil and criminal, have not changed since the last Disclosure Statement that was filed with ADEQ on 6/5/12



**6. Describe the experience and credentials of the Applicant, including the receipt of any past or present permits, licenses, certifications or operational authorization relating to environmental regulation. (Attach additional pages, if necessary.)**

C & H Hog Farms, Inc has been in operation for over two years. Prior to that time, Richard and Philip Campbell jointly operated C & C Hog Barn for twelve (12) years.

C & H Hog Farms, Inc operates in full compliance with state and federal regulations and currently holds a Regulation 6 permit.

**7. List and explain all civil or criminal legal actions by government agencies involving environmental protection laws or regulations against the Applicant \* in the last ten (10) years including:**

1. Administrative enforcement actions resulting in the imposition of sanctions;
2. Permit or license revocations or denials issued by any state or federal authority;
3. Actions that have resulted in a finding or a settlement of a violation; and
4. Pending actions.

(Attach additional pages, if necessary.)

To date, there have been no civil or criminal legal actions by government agencies involving environmental protection laws or regulations against the applicant and affiliated persons in the past ten (10) years immediately preceding the filing of this application, nor have there been any administrative enforcement actions resulting in the imposition of sanctions, permit or license revocations or denials issued by any state or federal authority against Jason Henson, Richard Campbell, or Philip Campbell.

**\* Firms or other legal entities shall also include this information for all persons and legal entities identified in sections 8-16 of this Disclosure Statement.**

**8. List all officers of the Applicant. (Add additional pages, if necessary.)**

NAME: Jason Henson TITLE: President  
STREET: HC 72 Box 10  
CITY, STATE, ZIP: Mount Judea, AR 72655

NAME: Richard Campbell TITLE: Vice-President  
STREET: P.O. Box 45  
CITY, STATE, ZIP: Vendor, AR 72683

NAME: Philip Campbell TITLE: Secretary  
STREET: P.O. Box 41  
CITY, STATE, ZIP: Vendor, AR 72683

**9. List all directors of the Applicant. (Add additional pages, if necessary.)**

NAME: Jason Henson TITLE: President  
STREET: HC 72 Box 10  
CITY, STATE, ZIP: Mount Judea, AR 72655

NAME: Richard Campbell TITLE: Vice-President  
STREET: P.O. Box 45  
CITY, STATE, ZIP: Vendor, AR 72683

NAME: Philip Campbell TITLE: Secretary  
STREET: P.O. Box 41  
CITY, STATE, ZIP: Vendor, AR 72683

**10. List all partners of the Applicant. (Add additional pages, if necessary.)**

NAME: Jason Henson TITLE: President  
STREET: HC 72 Box 10  
CITY, STATE, ZIP: Mount Judea, AR 72655

NAME: Richard Campbell TITLE: Vice-President  
STREET: P.O. Box 45  
CITY, STATE, ZIP: Vendor, AR 72683

NAME: Philip Campbell TITLE: Secretary  
STREET: P.O. Box 41  
CITY, STATE, ZIP: Vendor, AR 72683

**11. List all persons employed by the Applicant in a supervisory capacity or with authority over operations of the facility subject to this application.**

NAME: Jason Henson TITLE: President  
STREET: HC 72 Box 10  
CITY, STATE, ZIP: Mount Judea, AR 72655

NAME: Richard Campbell TITLE: Vice-President  
STREET: P.O. Box 45  
CITY, STATE, ZIP: Vendor, AR 72683

NAME: Philip Campbell TITLE: Secretary  
STREET: P.O. Box 41  
CITY, STATE, ZIP: Vendor, AR 72683

12. List all persons or legal entities, who own or control more than five percent (5%) of the Applicant's debt or equity.

NAME: Jason Henson TITLE: President

STREET: HC 72 Box 10

CITY, STATE, ZIP: Mount Judea, AR 72655

NAME: Richard Campbell TITLE: Vice-President

STREET: P.O. Box 45

CITY, STATE, ZIP: Vendor, AR 72683

NAME: Philip Campbell TITLE: Secretary

STREET: P.O. Box 41

CITY, STATE, ZIP: Vendor, AR 72683

13. List all legal entities, in which the Applicant holds a debt or equity interest of more than five percent (5%).

NAME: TITLE:

STREET:

CITY, STATE, ZIP:

NAME: TITLE:

STREET:

CITY, STATE, ZIP:

NAME: TITLE:

STREET:

CITY, STATE, ZIP:

14. List any parent company of the Applicant. Describe the parent company's ongoing organizational relationship with the Applicant.

NAME:

STREET:

CITY, STATE, ZIP:

Organizational Relationship:

15. List any subsidiary of the Applicant. Describe the subsidiary's ongoing organizational relationship with the Applicant.

NAME:

STREET:

CITY, STATE, ZIP:

Organizational Relationship:



16. List any person who is not now in compliance or has a history of noncompliance with the environmental laws or regulations of this state or any other jurisdiction and who through relationship by blood or marriage or through any other relationship could be reasonably expected to significantly influence the Applicant in a manner which could adversely affect the environment.

NAME: \_\_\_\_\_ TITLE: \_\_\_\_\_

STREET: \_\_\_\_\_

CITY, STATE, ZIP: \_\_\_\_\_

NAME: \_\_\_\_\_ TITLE: \_\_\_\_\_

STREET: \_\_\_\_\_

CITY, STATE, ZIP: \_\_\_\_\_

17. List all federal environmental agencies and any other environmental agencies outside this state that have or have had regulatory responsibility over the Applicant.

**18. VERIFICATION AND ACKNOWLEDGEMENT**

The Applicant agrees to provide any other information the director of the Arkansas Department of Environmental Quality may require at any time to comply with the provisions of the Disclosure Law and any regulations promulgated thereto. The Applicant further agrees to provide the Arkansas Department of Environmental Quality with any changes, modifications, deletions, additions or amendments to any part of this Disclosure Statement as they occur by filing an amended Disclosure Statement.

**DELIBERATE FALSIFICATION OR OMISSION OF RELEVANT INFORMATION FROM DISCLOSURE STATEMENTS SHALL BE GROUNDS FOR CIVIL OR CRIMINAL ENFORCEMENT ACTION OR ADMINISTRATIVE DENIAL OF A PERMIT, LICENSE, CERTIFICATION OR OPERATIONAL AUTHORIZATION.**

**COMPLETE THIS SECTION ONLY IF SUBMITTING OTHER THAN BY EPORTAL:**

I, Jason Henson \_\_\_\_\_, certify under penalty of law that this document and all attachments were prepared under my direction or supervision in accordance with a system designed to assure that qualified personnel properly gather and evaluate the information submitted. Based on my inquiry of the person or persons who manage the system, or those persons directly responsible for gathering the information, the information submitted is, to the best of my knowledge and belief, true, accurate, and complete. I am aware that there are significant penalties for submitting false information, including the possibility of fines and imprisonment for knowing violation.

**APPLICANT**

**SIGNATURE:** Jason Henson

**TITLE:** President

**DATE:** 5/7/15