



NPDES PERMIT FILE  
NPDES # ARR152371  
AFIN # 58-00762  
\_\_\_\_ Permit  
\_\_\_\_ Correspondence  
        Technical  
4-30-08 Date scanned & Init  
MR

## Storm Water Pollution Prevention Plan (SWPPP) Completeness Checklist

**Permittee:** Entergy Services, Inc.  
**Project Name:** Pleasant Hills to ANO Em. Rebuild  
**Project City:** Atkins

**Tracking Number:** ARR15 2371

Yes No N/A

Notes

**A. A site description, including:**

|                                     |                                     |  |   |
|-------------------------------------|-------------------------------------|--|---|
| <input checked="" type="checkbox"/> |                                     |  | 1. The nature of the activity?  |
| <input checked="" type="checkbox"/> |                                     |  | 2. Intended sequence of major construction activities.                |
| <input checked="" type="checkbox"/> |                                     |  | 3. The total area of the site.  |
| <input checked="" type="checkbox"/> |                                     |  | 4. The area of the site that is expected to undergo excavation.       |
| <input checked="" type="checkbox"/> |                                     |  | 5. The runoff coefficient of the site after construction is complete. |
| <input checked="" type="checkbox"/> |                                     |  | 6. Existing soil or storm water data.                                 |
| <input checked="" type="checkbox"/> | <input checked="" type="checkbox"/> |  | 7. Endangered Species information.                                    |

Part II.A.4.a.i  
Part II.A.4.a.ii  
Part II.A.4.a.iii  
Part II.A.4.a.iii  
Part II.A.4.a.iv  
Part II.A.4.a.iv  
Part II.A.4.a.vii, Must have US Fish & Wildlife clearance letter.

**B. Site Map showing:**

|                                     |  |  |   |
|-------------------------------------|--|--|---|
| <input checked="" type="checkbox"/> |  |  | 1. Drainage patterns.   |
| <input checked="" type="checkbox"/> |  |  | 2. Approximate slopes after major grading.                    |
| <input checked="" type="checkbox"/> |  |  | 3. Area of soil disturbance.                                  |
| <input checked="" type="checkbox"/> |  |  | 4. Outline of areas which will not be disturbed.              |
| <input checked="" type="checkbox"/> |  |  | 5. Location of major structural and non-structural controls.  |
| <input checked="" type="checkbox"/> |  |  | 6. Areas where stabilization practices are expected to occur. |
| <input checked="" type="checkbox"/> |  |  | 7. Surface waters.  |
| <input checked="" type="checkbox"/> |  |  | 8. Storm water discharge locations.                           |
| <input checked="" type="checkbox"/> |  |  | 9. The name of the receiving water(s).                        |

Part II.A.4.a.v  
Part II.A.4.a.v  
Part II.A.4.a.v  
Part II.A.4.a.v  
Part II.A.4.a.v  
Part II.A.4.a.v  
Part II.A.4.a.v  
Part II.A.4.a.v  
Part II.A.4.a.vi

**C. Description of Controls:**

|                                     |                                     |                                     |  |
|-------------------------------------|-------------------------------------|-------------------------------------|--|
| <input checked="" type="checkbox"/> |                                     |                                     | 1. Erosion and sediment controls, including:   |
|                                     |                                     |                                     | a) Stabilization practices for all areas disturbed by construction.  |
| <input checked="" type="checkbox"/> |                                     |                                     | b) Structural practices for all drainage/discharge locations.  |
|                                     | <input checked="" type="checkbox"/> |                                     | c) Does construction site have >=10ac draining to a common drainage location?  |
|                                     |                                     | <input checked="" type="checkbox"/> | d) If yes, description and placement of sedimentation basin.   |
|                                     |                                     | <input checked="" type="checkbox"/> | i) Sediment basin dimensions and capacity description and calculations.  |
|                                     |                                     | <input checked="" type="checkbox"/> | ii) Sediment basin outfall type, size, capacity, etc. calculations.  |
| <input checked="" type="checkbox"/> |                                     |                                     | 2. Storm Water management controls, including:   |
|                                     |                                     |                                     | a) Measures used to control pollutants occurring in storm water discharges after construction activities are complete.                   |
| <input checked="" type="checkbox"/> |                                     |                                     | b) Velocity dissipation devices to provide non-erosive flow conditions from the discharge point along the length of any outfall channel. |
| <input checked="" type="checkbox"/> | <input checked="" type="checkbox"/> |                                     | 3. Other controls including:   |
|                                     | <input checked="" type="checkbox"/> |                                     | a) Waste disposal practices which prevent discharge of solid materials to waters of the U. S.?   |
| <input checked="" type="checkbox"/> | <input checked="" type="checkbox"/> |                                     | b) Measures to minimize offsite tracking of sediments by construction vehicles.  |
| <input checked="" type="checkbox"/> | <input checked="" type="checkbox"/> |                                     | c) Measures to ensure compliance with State or local waste disposal, sanitary sewer, or septic system regulations.                       |
| <input checked="" type="checkbox"/> |                                     |                                     | 4. Description of the timing during the construction when measures will be implemented.  |

Part II.A.4.b.i.A  
Part II.A.4.b.i.B  
Part II.A.4.b.i.B(1) & (2)  
Part II.A.4.b.i.B(1) & (2)  
Part II.A.4.b.i.B(1) & (2)  
Part II.A.4.b.i.B(1) & (2)  
Part II.A.4.b.ii  
Part II.A.4.b.ii.B  
Part II.A.4.b.iii.A, Must describe waste control practices.  
Part II.A.4.b.iii.B, Must include stabilized construction exits onto paved roads.  
Part II.A.4.b.iii.C, Portable toilets?  
Part II.A.4.b

## Storm Water Pollution Prevention Plan (SWPPP) Completeness Checklist

**Permittee:** Entergy Services, Inc.  
**Project Name:** Pleasant Hills to ANO Em. Rebuild  
**Project City:** Atkins

**Tracking Number:** ARR15 2371

**D. Are State or local requirements incorporated into the plans?**

Part II.A.4.c

**E. Are maintenance procedures for control measures identified in the plan?**

Part II.A.4.d, Must describe when and how controls will be maintained, ie, silt 1/3 height of silt fence and 48 hrs after discovery.

**F. Are inspection procedures identified in the plan?**

Part II.A.4.e, Must state that inspections will be conducted every 7 days and within 24hr after a 1/2" rainfall.

a) Name of qualified inspector identified?

Part II.A.4.e, Must include the name of the qualified inspector, if not chosen must include a statement with the inspector certification that it will be signed prior to construction activity.

b) Signed Inspector qualification certification included?

Part II.A.4.e, The certification must be signed or contain a statement that it will be signed prior to construction activity.

c) Inspection form included w/ certification?

Part II.A.4.e

**G. Documentation of permit eligibility related to Total Maximum Daily Loads (TMDL).**

Part II.A.4.f, Must state whether or not the receiving stream is impaired.

**H. Documentation of attainment of Water Quality Standards after authorization.**

Part II.A.4.g, Must document that water quality standards will be met.

**I. Identification of allowable non-storm water discharges identified in the plan?**

Part II.A.5, Fire fighting, water line flushings, etc.?

**J. Signed Contractor certification.**

Part II.A.6, Must include the exact contractor certification from the permit and either be signed or include a statement that it will be signed prior to construction.

**K. Signed Plan certification.**

Part II.A.2 & Part II.B.10, Must include the exact certification from the permit and be signed by the permittee.

Document No. 080047  
PBS&J Job No. 100001086

**STORM WATER POLLUTION PREVENTION PLAN**  
**ENTERGY SERVICES, INC.**  
**PLEASANT HILLS TO ANO EMERGENCY REBUILD**  
**POPE COUNTY, ARKANSAS**

Prepared for:

Entergy Services, Inc.  
425 W. Capitol Avenue  
Little Rock, AR 72203

Prepared by:

PBS&J  
909 ESE Loop 323  
Suite 360  
Tyler, Texas 75701

March 2008

*Printed on recycled paper*

# Contents

|   | Page       |
|---|------------|
| List of Figures .....                                       | iv         |
| List of Tables .....  | v          |
| <b>1.0 INTRODUCTION .....</b>                               | <b>1-1</b> |
| 1.1 STORM WATER PLAN AND COMPLIANCE PROGRAM .....           | 1-1        |
| 1.2 OWNER, CONTRACTOR, REPRESENTATIVE INFORMATION .....     | 1-1        |
| 1.3 PROJECT DESCRIPTION .....                               | 1-2        |
| 1.4 RETENTION OF RECORDS .....                              | 1-2        |
| 1.5 FINAL STABILIZATION .....                               | 1-2        |
| <b>2.0 CONSTRUCTION.....</b>                                | <b>2-1</b> |
| 2.1 DESCRIPTION OF CONSTRUCTION ACTIVITIES .....            | 2-1        |
| 2.2 CONSTRUCTION SEQUENCE .....                             | 2-1        |
| 2.3 POTENTIAL POLLUTANTS .....                              | 2-1        |
| 2.4 SITE MAPS .....   | 2-2        |
| 2.5 NAME OF RECEIVING WATERS.....                           | 2-2        |
| 2.6 RUNOFF COEFFICIENT .....                                | 2-2        |
| 2.7 SOILS .....   | 2-3        |
| 2.8 ENDANGERED SPECIES.....                                 | 2-3        |
| 2.9 TOTAL MAXIMUM DAILY LOAD (TMDL) AND WATER QUALITY ..... | 2-3        |
| <b>3.0 EROSION AND SEDIMENTATION CONTROLS .....</b>         | <b>3-1</b> |
| 3.1 EROSION AND SEDIMENTATION CONTROL .....                 | 3-1        |
| 3.1.1 Preservation of Natural Vegetation (Buffer Zone)..... | 3-1        |
| 3.1.2 Silt Fence/Hay/Straw Bale Installation.....           | 3-1        |
| 3.1.3 Mulch.....  | 3-1        |
| 3.1.4 Interceptor Dikes.....                                | 3-2        |
| 3.2 RIGHT-OF-WAY RESTORATION AND REVEGETATION .....         | 3-2        |
| 3.2.1 Cleanup.....  | 3-2        |
| 3.2.2 Revegetation and Seeding.....                         | 3-2        |
| 3.2.3 Control of Off-Road Vehicles .....                    | 3-3        |
| 3.3 OTHER POLLUTION PREVENTION CONTROLS .....               | 3-3        |
| 3.4 ALLOWABLE NON-STORM WATER DISCHARGES .....              | 3-4        |
| <b>4.0 MAINTENANCE/INSPECTIONS AND EVALUATION.....</b>      | <b>4-1</b> |
| 4.1 MAINTENANCE/INSPECTION PROCEDURES .....                 | 4-1        |
| 4.2 EVALUATION .....  | 4-2        |

## Appendices:

- A Photographs
- B Site Plan
- C Inspection Report Forms
- D Erosion and Sediment Control Measures Construction Specification

|   |                               |
|---|-------------------------------|
| E | Notice of Termination Form    |
| F | Contractor Certification Form |
| G | Agency Coordination           |

**Figures**

|   |                           | <b>Page</b> |
|---|---------------------------|-------------|
| 1 | Project Vicinity Map..... | 1-3         |
| 2 | Project Location Map..... | 1-4         |

**Tables**

|  | <b>Page</b> |
|--|-------------|
| 1      Runoff Coefficients for Three Storm-Event Return Periods..... | 2-3         |

## 1.0 INTRODUCTION

---

### 1.1 STORM WATER PLAN AND COMPLIANCE PROGRAM

This document establishes a plan to restore the construction site to pre-construction contours, manage the quality of storm water runoff through proper placement of control structures, establish vegetation goals, and set monitoring and reporting requirements associated with the Pleasant Hills to ANO Emergency Rebuild Project. This Storm Water Plan is required by the Arkansas Department of Environmental Quality and is authorized under Permit No. ARR150000. Compliance with NPDES will ensure Entergy's commitment to federal, state, and local agency programs (e.g. Clean Water Act, and The Arkansas Water and Air Pollution Control Act Relating to Discharges from Construction Activities) remains intact.

This storm water plan establishes a program by which sediments and other potential pollutants from construction activities can be substantially prevented from entering downstream receiving waters. Specific controls for this project will be developed and marked on the site map included in this plan. This plan is a living document and should be modified to adjust for field conditions as they might change during implementation. It is the responsibility of Entergy, through its representative PBS&J, to keep this plan up-to-date to ensure the control of pollutants in storm water discharges associated with construction activities.

### 1.2 OWNER, CONTRACTOR, REPRESENTATIVE INFORMATION

**Owner Address:**

Entergy Services, Inc.  
425 W. Capitol Avenue  
Little Rock, AR 72203  
501-352-7497

**Contractor Address:**

Richard Baughn Construction, Inc.  
405 SW Drive, Suite A-170  
Jonesboro, AR 72401  
870-910-5176

**Owner Representative Address:**

PBS&J  
909 ESE Loop 323, Suite 360  
Tyler, TX 75701  
903-509-1552

---

### **1.3 PROJECT DESCRIPTION**

On February 5, 2008, a category F4 tornado (Fujita scale) destroyed seven electric transmission line towers on Entergy's existing Pleasant Hills to ANO 345kV electric transmission line in Blackwell, Pope County, Arkansas. The approximate midpoint of the impact area (150 foot by 9,500 foot (32.71 acres) is: Latitude: 35° 16' 13" North Longitude: 92° 51' 59" West (Figures 1 and 2). The line service is critical, as it is a direct line to two large Electric High Voltage (EHV) yards. An EHV yard transitions electricity from power plant along a 500kV line and transmits across the state. This line in particular supplied Pleasant Hills EHV which in turn supplies Little Rock, Arkansas, and connects to the Transmission Reliability Grid covering the United States. On February 6, 2008, President George W. Bush declared the area a national disaster area. Concurrently, Entergy began site evaluations to assess the damage and initiate recovery operations. Equipment was mobilized to the site on February 7-10, 2008, and rebuild began immediately. On February 24, 2008, the line was back in service, and by February 28, 2008 all equipment was removed. Elapsed time was 23 days.

The site is generally rolling pasture, mixed upland pine-hardwoods, and riparian corridors associated with major streams. Wetlands occur occasionally in the landscape. The site has enough topographic relief to allow for sufficient runoff. However, during rebuild efforts, the construction site received several days of rain totaling more than four inches, including one day with over two and half inches of rain. Thus several areas within the existing 150-foot wide ROW became saturated or inundated and ground conditions deteriorated rapidly. Every effort was made during the rebuild to minimize impacts to the environment. However, repeated travel with heavy equipment across saturated ground created several areas where the surface soils became unconsolidated. Within these unconsolidated areas, vegetation was impacted, soil structure was altered, and sediment was suspended in the water column creating the potential to enter downstream receiving waters. Other pollutants ancillary to the construction process may have entered receiving waters (e.g. oils and greases).

### **1.4 RETENTION OF RECORDS**

If the site is inactive or does not have an on-site location to store the plan, Entergy will post a notice near the main entrance of the construction site that will identify the location of the plan. From the date of project completion to final stabilization, a copy of the plan will be maintained and available for agency and/or public review. Entergy shall retain copies of the plan and all reports for a period of at least three years from the date that final stabilization was completed.

### **1.5 FINAL STABILIZATION**

"Final stabilization" means that all soil disturbing activities at the site have been completed, and that a uniform perennial vegetative cover with a density of 70 percent has been established or equivalent permanent stabilization measures (such as the use of riprap, gabions, or geotextiles) have been employed on all unpaved areas. When the site has been finally stabilized and all storm water discharges associated with construction activities have been eliminated Entergy may cease inspections of the site.

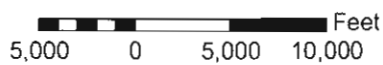
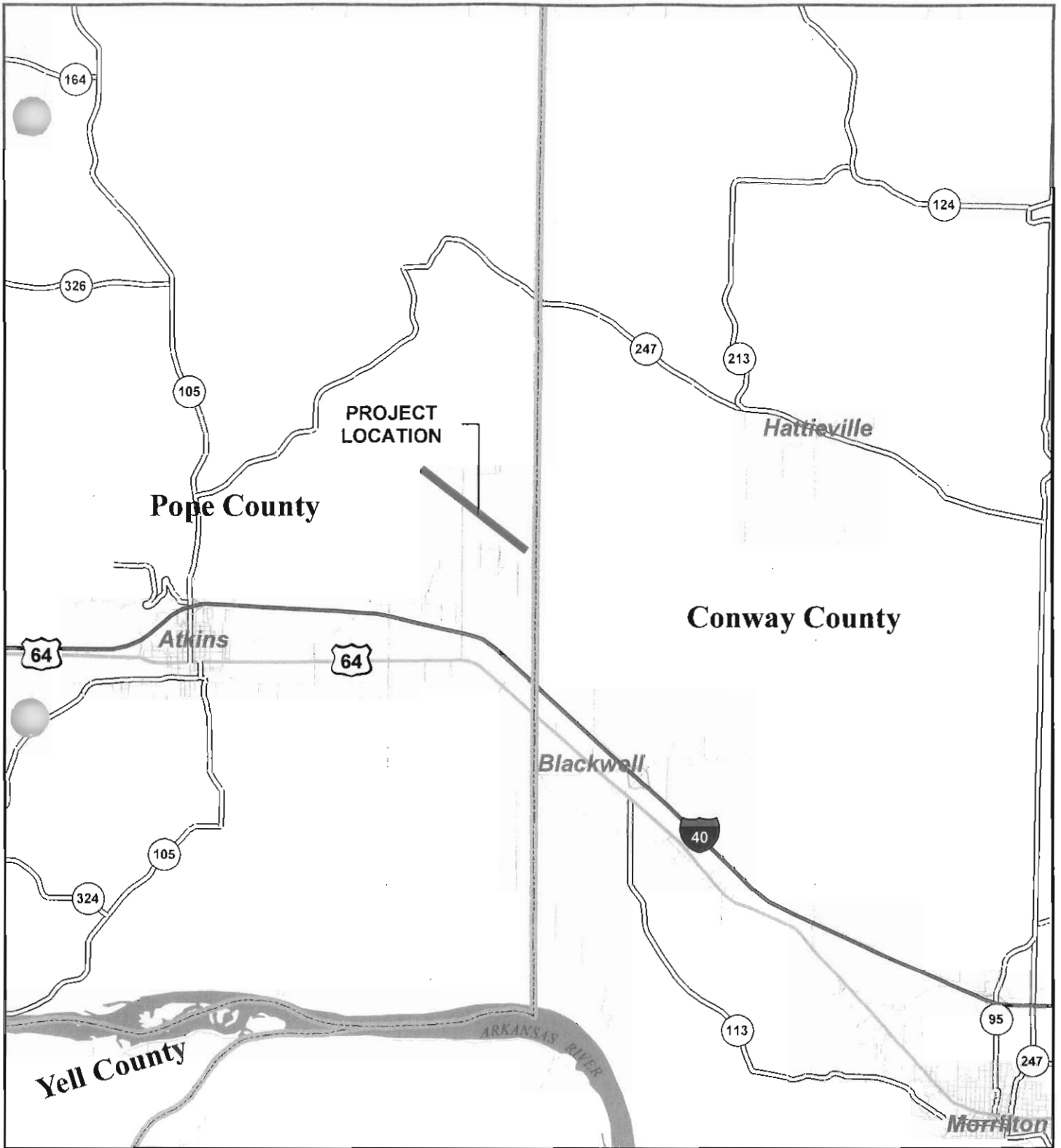

FIGURE 1  
VICINITY MAP  
PLEASANT HILLS TO ANO EMERGENCY REBUILD  
ENTERGY SERVICES, INC.  
POPE COUNTY, ARKANSAS



## **2.0 CONSTRUCTION**

---

### **2.1 DESCRIPTION OF CONSTRUCTION ACTIVITIES**

Electric transmission lines are generally constructed by both conventional ground equipment and/or helicopter. The Pleasant Hills to ANO Emergency Rebuild Project utilized helicopters to remove damaged structures, and install new or repaired structures. Conventional ground equipment such as dozers, trucks, and low-impact type equipment (i.e. Mantis and Marsh Buggies) were utilized by foundation crews, line crews, cut in crews, and additional work crews to gain access to the work site and complete the rebuild. The low-impact equipment was also used to transport materials up and down the ROW, especially in wet areas. Ground crews cleared ROW of storm debris, repaired foundations, assembled structures, and prepared new line for installation.

### **2.2 CONSTRUCTION SEQUENCE**

On February 6, 2008, President Bush declared the area a national disaster area; Concurrently, Entergy began site evaluations. Equipment was brought in February 7–10, 2008, and repairs began immediately. On February 24, 2008, the line was back in service, and on February 28, 2008 all equipment was removed. Repair of the Pleasant Hills to ANO electric line proceeded as follows:

- ROW cleared, including removing debris from the tornado;
- Removal of damaged structures, including line and concrete foundation footholds;
- Assembly or repair of structures on the ground;
- Repair of foundation footholds;
- Installation of structures by helicopter;
- Installation of new line;
- Rough cleanup and grading; and
- Restoration of the construction ROW.

### **2.3 POTENTIAL POLLUTANTS**

The primary pollutant source from the project is disturbed soils suspended in the water column within the construction ROW. Other potential pollutant sources include debris from the clearing operations and petroleum products needed for the construction equipment. Soil disturbing activities during construction consisted primarily of vegetation clearing, grading, and rubber tired/tracked vehicle movement. Where ground disturbance required erosion protection, temporary control devices were installed to control the erosive force of the runoff. Where possible, ground disturbance during clearing and construction was limited to prevent erosion/sedimentation and to facilitate restoration efforts.

---

Excessive amounts of sediments found to have washed down hill slopes into creeks or low points will be returned to the hill slopes to prevent sedimentation of downstream areas. Areas disturbed by construction activity will be graded to restore the easement to near its original grade. Sediment barriers such as silt fencing or straw/hay bales were placed at appropriate locations to reduce soil loss. These sediment controls will be left in place or replaced/repared until the site has reached final stabilization.

## **2.4 SITE MAPS**

Plan and profile sheets along with aerial and topographic maps of the project area serve as site maps for the restoration plan. Site maps will be prepared under the direction of Entergy specifically for the Pleasant Hills to ANO Emergency Rebuild project and illustrate the recommended location of erosion and sedimentation control devices as indicated by actual field conditions. Once prepared with specific controls assigned, site maps must be updated and kept with the restoration plan to complete the document. Site maps will clearly identify areas where ground-disturbing activities occurred, and the general location of erosion and sedimentation control structures. The site map requirements also include identification of drainage patterns, location of areas where stabilization practices are required, surface waters, wetlands, and locations where storm water is discharged to a surface water and wetland.

## **2.5 NAME OF RECEIVING WATERS**

The project ROW drains to Gum Log Creek and White Oak Creek on the west end of the project and Goose Pond on the east end of the project. All receiving waters drain to West Fork Point Remove Creek.

## **2.6 RUNOFF COEFFICIENT**

The runoff coefficient “C” is the ratio of the volume of storm water runoff from the site compared to the total volume of precipitation that falls on the site. The General Permit requires an estimate of this ratio that will represent rainfall runoff conditions after construction activities are complete and the area is finally stabilized. Native vegetation will be restored, except for those trees within the permanent construction easement. Therefore, the estimate of the project’s post development “C” value will be roughly equivalent to the predevelopment conditions.

The estimate of “C” is based on variables from three general terrain categories: 1) soil properties (porosity, density, etc.); 2) ground slope; and 3) the character of vegetative cover (woodlands, pasture, grassland, etc.).

A fourth major variable effecting “C” is rainfall intensity. For any given terrain, the ratio of runoff to rainfall is expected to increase as storm intensity increases. Generally speaking, storm water controls should be installed, inspected, and maintained to control a two-year, 24-hour rain event.

To address the NPDES permit requirement, an estimate of the post development runoff coefficient must be made for each “site” along the project. Sites that are represented by a single “C” value are consistent in soil type, ground slope, and ground cover. The estimate is based on field observations and construction plans (alignment sheets). A table of typical runoff coefficient values is presented in Table 1:

Table 1,  
Runoff Coefficients for Three Storm Event Return Periods

| Undeveloped Conditions | 2-year | 10-year | 25-year |
|------------------------|--------|---------|---------|
| Cultivated Land        |        |         |         |
| Flat, 0–2%             | 0.31   | 0.36    | 0.40    |
| Average, 2–7%          | 0.35   | 0.41    | 0.44    |
| Steep, over 7%         | 0.39   | 0.44    | 0.48    |
| Pasture Land           |        |         |         |
| Flat, 0–2%             | 0.25   | 0.30    | 0.34    |
| Average, 2–7%          | 0.33   | 0.38    | 0.42    |
| Steep, over 7%         | 0.37   | 0.42    | 0.46    |
| Forest/Woodlands       |        |         |         |
| Flat, 0–2%             | 0.22   | 0.28    | 0.31    |
| Average, 2–7%          | 0.31   | 0.36    | 0.40    |
| Steep, over 7%         | 0.35   | 0.41    | 0.45    |

The runoff coefficient for this project is 0.33 to 0.42 based on the above table.

## 2.7 SOILS

Four soils types can be found throughout the project site. These soils are Guthrie silt loam, 0–1 percent slopes; Pickwick silt loam, 3–8 percent slopes; Taft silt loam, 0–2 percent slopes; and Muskogee silt loam, 1–3 percent slopes.

## 2.8 ENDANGERED SPECIES

The gray myotis (*Myotis grisescens*), Arkansas River Shiner (*Notropis girardi*), and the Interior Least Tern (*Sterna antillarum athalassos*) are currently listed as threatened or endangered within Pope County, Arkansas. However, habitat within the project site was not observed. During the construction activities, a qualified biologist visited the project location and did not identify the location and extent of individuals, colonies, or potential critical habitats of federal/state listed threatened or endangered (T&E) species (within the project area) identified by the United States Fish and Wildlife Service (USFWS) and protected under the Endangered Species Act. A copy of the US Fish and Wildlife consultation letter can be found in Appendix G. A copy of the clearance letter will be forwarded upon receipt.

## 2.9 TOTAL MAXIMUM DAILY LOAD (TMDL) AND WATER QUALITY

The receiving waters are tributaries to West Fork Point Remove Creek. West Fork Point Remove Creek does not have an associated TMDL. The overall protection of the water quality standards was considered when the Best Management Practices were chosen and this Plan was prepared. The implementation of this Plan will ensure that the discharges do not cause or contribute to an excursion above any applicable water quality standards.

## 3.0

## EROSION AND SEDIMENTATION CONTROLS

---

The primary objectives of the erosion and sedimentation controls are to protect water quality in streams and stream side habitats, to prevent soil erosion due to water runoff and wind, and to return disturbed upland areas to agricultural production or natural vegetation as quickly as possible following construction, with as little soil loss as possible. Erosion and sedimentation controls placed in waters of the United States, including wetlands are subject to Section 404 of the Clean Water Act and should be avoided. Please see Appendix D for Entergy's "Erosion and Sediment Control Measures Construction Specification" manual for control measure guidelines. The recommended structural erosion and sedimentation control practices may include the following items.

### 3.1 EROSION AND SEDIMENTATION CONTROL

#### 3.1.1 Preservation of Natural Vegetation (Buffer Zone)

The preservation of natural vegetation (existing trees, shrubs, and herbaceous vegetation) provides natural buffer zones. By preserving stabilized areas, erosion potential is minimized and water quality is protected. Preservation usually requires less maintenance than planting new vegetation. Vegetation buffer zones adjacent to the wetlands and stream banks will be kept in place. Natural vegetation will be utilized to the greatest extent possible in all other areas.

#### 3.1.2 Silt Fence/Hay/Straw Bale Installation

Silt fence will be imbedded a minimum of four inches into the soil surface, and where two sections are joined, overlapped a minimum of six inches. Accumulated sediment will be removed regularly and the fence inspected to ensure that the bottom of the fence remains imbedded in the ground.

Hay/straw bales will be anchored in place with two stakes, the first stake driven at an angle toward previously positioned bale, and the second stake driven perpendicular to the ground surface. Bindings on bales will be horizontal and shall not consist of wire. Bales will be replaced if damaged or if water is channeling underneath bales. An adequate supply of bales will be stockpiled on site for immediate needs or routine placement.

Silt fence/hay/straw bales shall be placed as indicated on site maps. Additional silt fence/hay/straw bales may need to be installed as field conditions warrant.

#### 3.1.3 Mulch

Mulching is a temporary soil stabilization and erosion control method, which utilizes materials such as grass, hay, wood chips, wood fibers, or straw placed on the soil surface for stabilization. Mulching reduces the velocity of storm water runoff thereby reducing its erosive forces; it aids plant growth by anchoring the seeds, fertilizers and topsoil in place; it retains soil moisture, and insulates against extreme

---

temperatures. Mulching can provide immediate and effective erosion control on the ROW. Mulch can be easily blown or washed away and, as a result, requires regular inspection.

Mulch should be applied on all slopes within 100 feet of water bodies and wetlands to a rate of no more than three tons/acre. If wood chips are used as mulch, do not use more than one ton/acre and the addition of nitrogen (at least 50 percent of which is slow release) may need to be added.

If a mulch blower is used, the strands of the mulching material shall be at least 8 inches long to allow anchoring to minimize loss by wind and water. When anchoring by mechanical methods, use a mulch anchoring tool to properly crimp the mulch to a depth of 2–3 inches. When anchoring with liquid mulch binders, use rates recommended by the manufacturer.

### **3.1.4 Interceptor Dikes**

At this time no interceptor dikes are planned for installation. However, monitoring results may indicate interceptor dikes are necessary to reduce runoff velocity and divert water off the construction ROW. If necessary, interceptor dikes may be constructed of materials such as compacted soil and sandbags.

Interceptor dikes should be constructed and maintained in all areas, except cultivated areas and lawns. Interceptor dikes should be constructed with a 2–5 percent out slope to divert surface flow to a stable area. In the absence of a stable area, construct an energy-dissipating device at the end of the interceptor dike.

## **3.2 RIGHT-OF-WAY RESTORATION AND REVEGETATION**

Restoration of the ROW will begin after construction activities have been completed. Restoration measures are permanent measures to assure that natural drainage patterns reestablish themselves and post-construction erosion is avoided. Property should be restored in accordance with land owner agreements. Elevations in jurisdictional wetlands and other waters of the U.S. require restoration of preconstruction contours. The following items will be conducted as soon as practicable.

### **3.2.1 Cleanup**

Remove construction debris from the ROW and grade or till the ROW to leave the soil in the proper condition for planting. Every effort to complete final cleanup of an area (including final grading and installation of permanent erosion control structures) should be completed as soon as possible. The disturbed ROW should be seeded as soon as possible after final grading as weather and soil conditions allow.

### **3.2.2 Revegetation and Seeding**

Temporary stabilization will be necessary in unconsolidated areas until they are dry enough to allow equipment to conduct proper grading activities. These areas should be seeded with Ryegrass and mulched with straw/hay.

---

Permanent stabilization consists of the final seeding of vegetation in all other disturbed, unvegetated areas affected by construction. The following guidelines will be useful in establishing permanent vegetation in those areas disturbed by construction activities.

Prepare the seedbed in disturbed areas to a depth of 3–4 inches using appropriate equipment (i.e., cultipacker, disc) to provide a firm seedbed. Seed disturbed areas with a seed mixture of fescue/rye/Bermuda grass in accordance with written recommendations for seed mixes, rates, and dates. Reseed all disturbed lawns with a seed mixture acceptable to landowner or comparable to the adjoining lawn.

Seed all disturbed soils within 14 days of final grading as weather and soil conditions allow. On slopes steeper than 30 percent, seed immediately after final grading, weather permitting. Base seeding rates on Pure Live Seed (PLS), and use seed within 12 months of seed testing.

Uniformly apply and cover seed in accordance with the written recommendations. In the absence of any recommendations, a seed drill equipped with a cultipacker is preferred for application, but broadcast or hydro seeding can be used at double the recommended seeding rates. Where seed is broadcast, firm the seedbed with a cultipacker or roller after seeding.

Where hand-broadcast seeding is used, the seed will be applied at half the doubled rate in each of the two separate passes. The passes will be made perpendicular to each other to ensure complete and uniform coverage.

### **3.2.3 Control of Off-Road Vehicles**

Off-road vehicles can be detrimental to successful restoration of a construction ROW. Off-road vehicles can destroy established vegetation and hay/straw fences and create ruts which allows for transportation of sediment or other pollutants to downstream receiving waters. One or more of the following measures, if warranted, will be used to control off-road vehicles:

- Posting appropriate signs.
- Installing a locking, heavy steel gate with fencing extending a reasonable distance to prevent bypassing the gate.
- Installing a slash and timber barrier, a pipe barrier, or a line of boulders across the ROW to limit unauthorized vehicle access.

All efforts to control off-road vehicle use will be implemented in cooperation with the landowner, and all signs, gates, and marker posts will be maintained as necessary.

## **3.3 OTHER POLLUTION PREVENTION CONTROLS**

**Entrances/Exits** - The construction entrances/exits and staging areas were cleaned regularly to keep them clear of materials and debris, and to minimize off-site tracking of sediments by construction vehicles.

**Waste Disposal** - The Contractor was responsible for removing waste from the site and proper disposal. Concrete trucks and other construction equipment were rinsed out as needed on site. The rinse sites

---

provided for soil infiltration of rinse water and no detergents were used. Sediment barriers were used as needed to prevent discharge of contact storm water from wash sites. Captured sediment from the wash sites was properly disposed. Trash was collected at the end of each day and disposed of off-site.

**State/Local Waste Disposal, Sanitary Sewer and Septic System Regulations** – All sanitary waste was collected in portable toilet and maintained in accordance with local and state regulations.

**Vehicle Inspection, Refueling Operations and Spill Control** - All construction vehicles were monitored for leaks and received proper preventive maintenance to reduce the chance of leakage. Petroleum products were stored properly, and spills were cleaned up immediately after discovery. However not all fluids can be contained during construction activities. On February 23, 2008, Micro-Blaze was used to mitigate hydraulic oil lost from buried equipment and at refueling sites. Micro-Blaze was applied at a rate of ten gal/acre. If necessary, Micro-Blaze should be applied to additional areas at the same rate of ten gal/acre.

**Material Storage** - Construction materials, construction chemicals and stockpiles of dirt and topsoil were stored in designated storage areas in a manner which prevented these materials from becoming a potential pollutant source in storm water discharge.

Stockpiled soils will be protected with sediment control fencing and/or stabilized with temporary vegetation or mulching. Construction materials and construction chemicals will be stored off of the ground surface (i.e. on pallets) and under protective cover. In addition, construction chemicals will be stored in the original manufacture's containers.

**Potential Pollutant Sources Other Than Construction** - There will be no anticipated storm water discharges at the project site other than the above-mentioned activities related to construction.

### **3.4 ALLOWABLE NON-STORM WATER DISCHARGES**

Certain types of discharges are allowable under ADEQ NPDES Permit No. ARR150000 for construction activities and it is the intent of this Plan to allow such discharges. These types of discharges will be allowed under the conditions that no pollutants will be allowed to come in contact with the water prior to or after its discharge. The control measures which have been outlined previously in this Plan will be strictly followed to ensure that no contamination of these non-storm water discharges takes place. The following allowable non-storm water discharges which may occur from this project include:

- Discharge from firefighting activities,
- Water used to wash vehicles or control dust in order to minimize offsite sediment tracking,
- Uncontaminated ground water or spring water, and
- Uncontaminated excavation dewatering.

## 4.0 MAINTENANCE/INSPECTIONS AND EVALUATION

---

### 4.1 MAINTENANCE/INSPECTION PROCEDURES

Once the controls are in place, PBS&J will provide qualified inspection personnel to inspect, monitor, and report on all control structures installed by the Contractor. This effort will include the following:

1. Oversee and ensure that proper site notices are posted at the entrance(s) to the work site.
2. Routine weekly inspections will be conducted every 7 days for the project control structures until the project site is stabilized.
3. Inspections will be conducted within 24 hours of the end of a one-half inch rainfall event.
4. After each inspection, prepare an inspection report documenting the current status of observed control measures, including any deficiencies or required modifications. An inspection report for each project will be given to the Contractor for his signature. Copies will be forwarded to the owner and recorded in the project files, which are available for agency review.
5. All measures will be maintained in good working order; if a repair is necessary, it will be initiated with 24 hours of the report.
6. Built-up sediment will be removed from silt fences when it has reached one-third the height of the fence.
7. Silt fences will be inspected for depth of sediment and tears to see if the fabric is securely attached to the stakes, and to see that the stakes are firmly in the ground
8. Hay bale structures will be inspected for proper anchoring, decay, and missing sections, and will be replaced if not properly working.
9. Permanent seeding and planting will be inspected for bare spots, washouts, and healthy growth.
10. Perform follow-up inspection after any required changes to the control structures have been implemented in the field by the Contractor and document these changes as "installed" on the appropriate alignment sheet(s).
11. Document instances of non-compliance by the Contractor and recommend compliance measures. Inform the Owner if the Contractor is not responsive to recommendations of PBS&J.
12. Maintain a project file of all inspections, changes to the plan, and other pertinent record information. Project files will be organized in an orderly fashion to facilitate agency review (e.g., ADEQ).
13. Serve as the Owner's agent and attend any project inspection visits performed by government agencies. Assist Entergy in answering questions submitted by agency review personnel.

---

## 4.2 EVALUATION

As needed, PBS&J will provide qualified professional personnel to evaluate and direct changes to all control structures installed by the Contractor. This effort will include the following:

1. Assist monitoring personnel in the evaluation of the effectiveness of the control structures installed by the Contractor.
2. Provide professional technical support to the project team.
3. Recommend modifications to the control structures in the event any existing controls are determined to be ineffective. Any required modifications or revisions will be documented in the restoration plan and filed accordingly.

**Appendix A**  
**Photographs**



Photo 1: Photograph is of an upland area located west of Tally Lane looking toward Gum Log Creek. See Site Map for location.

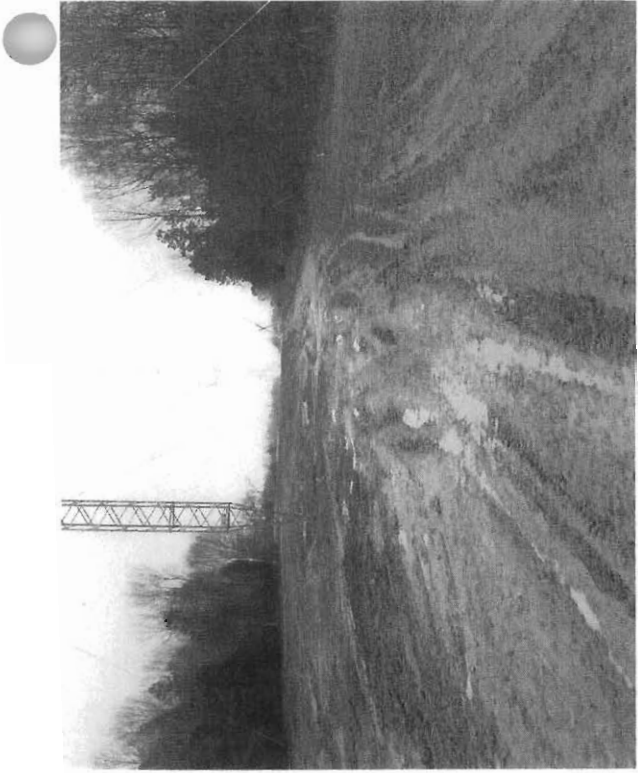

Photo 2: Photograph is of an upland area looking east toward staging area at Tally Lane. See Site Map for location.



Photo 3: Photograph of vegetation in wetland between Tally Lane and Gum Log Creek.



Photo 4: Photograph of vegetation in wetland between Tally Lane and Gum Log Creek. Notice water marks on trees several feet up.



Photo 5: Photograph of wetland located just east of Gum Log Creek. Photograph is looking west. Notice intact vegetation.



Photo 6: Photograph of wetland located just east of Gum Log Creek. Photograph is looking east. Notice intact vegetation.



Photo 7: Photograph of vegetation near Gum Log Creek.



Photo 8: Photograph of first tower and ROW east of Tally Lane. This is an upland area.



Photo 9: Photograph of upland area east of Tally Road. See Site Map for location.



Photo 10: Photograph of wetland associated with Goose Pond.



Photo 11: Photograph of staging area near east end of project.

**Appendix B**

**Site Plan**

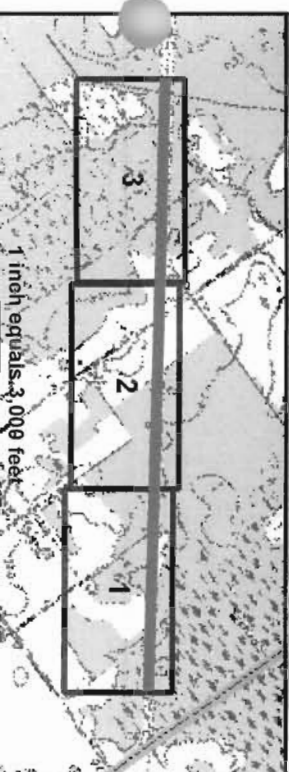

\* Note: Entire 150' ROW should be seeded with fescue/rye/bermuda grass mixture.

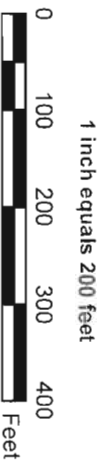

- |                                      |                     |
|--------------------------------------|---------------------|
| ● Photo location                     | — Transmission line |
| — Straw/Hay bales                    | ▨ Wetland area      |
| ▨ Area seeded and covered with straw | → Drainage pattern  |

SHEET 1 OF 3

Base Map: 2006 DOQQ Aerials, Hattiesville SW & Moreland SE



APPENDIX B1

SITE MAP

PLEASANT HILLS TO ANDO EMERGENCY REBUILD

ENERGY SERVICES, INC.

POPE COUNTY, ARKANSAS

PROJECT NO. 100001086

DATE: 04/22/08

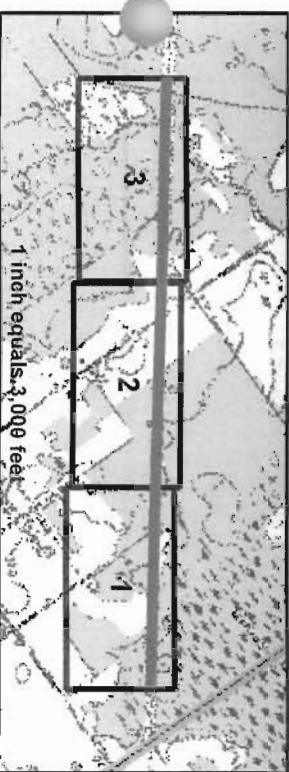

\* Note: Entire 150' ROW should be seeded with fescue/rye/bermuda grass mixture.



1 inch equals 200 feet  
 0 100 200 300 400 Feet

- Photo location
- Straw/Hay bales
- ▨ Area seeded and covered with straw
- Transmission line
- ▨ Wetland area
- Drainage pattern

SHEET 2 OF 3



APPENDIX B1  
 SITE MAP  
 PLEASANT HILLS TO ANO EMERGENCY REBUILD  
 ENERGY SERVICES, INC.  
 POPE COUNTY, ARKANSAS

Base Map: 2006 DOQQ Aerials, Hartsville SW & Moreland SE

PROJECT NO. 100001086

DATE: 04/22/08

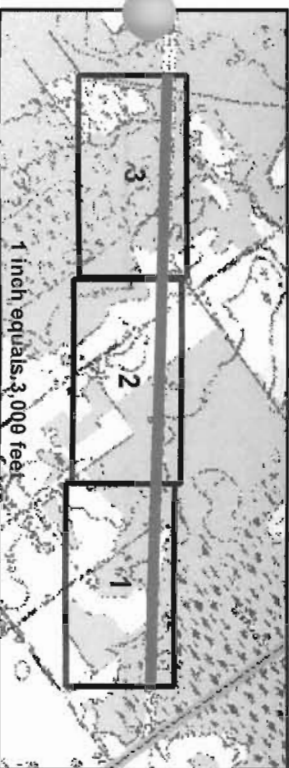

\* Note: Entire 150' ROW should be seeded with fescue/rye/bermuda grass mixture.

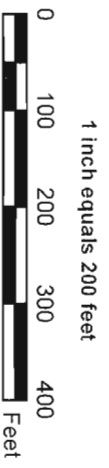

- Photo location
- Straw/Hay bales
- ▨ Area seeded and covered with straw
- Transmission line
- ▨ Wetland area
- Drainage pattern

SHEET 3 OF 3



APPENDIX B1  
 SITE MAP  
 PLEASANT HILLS TO ANO EMERGENCY REBUILD  
 ENTERGY SERVICES, INC.  
 POPE COUNTY, ARKANSAS

Base Map: 2006 DOQQ Aerials, Hartieville SW & Moreland SE

PROJECT NO. 100001086

DATE: 04/22/08

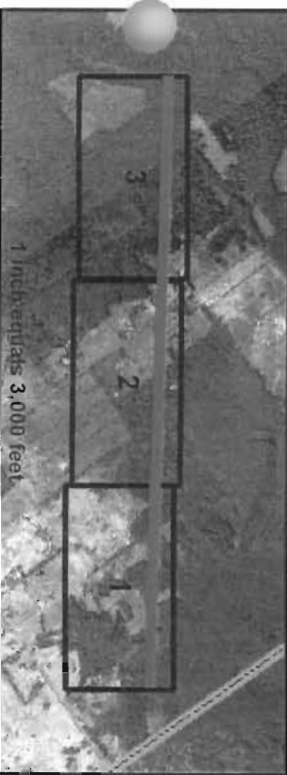
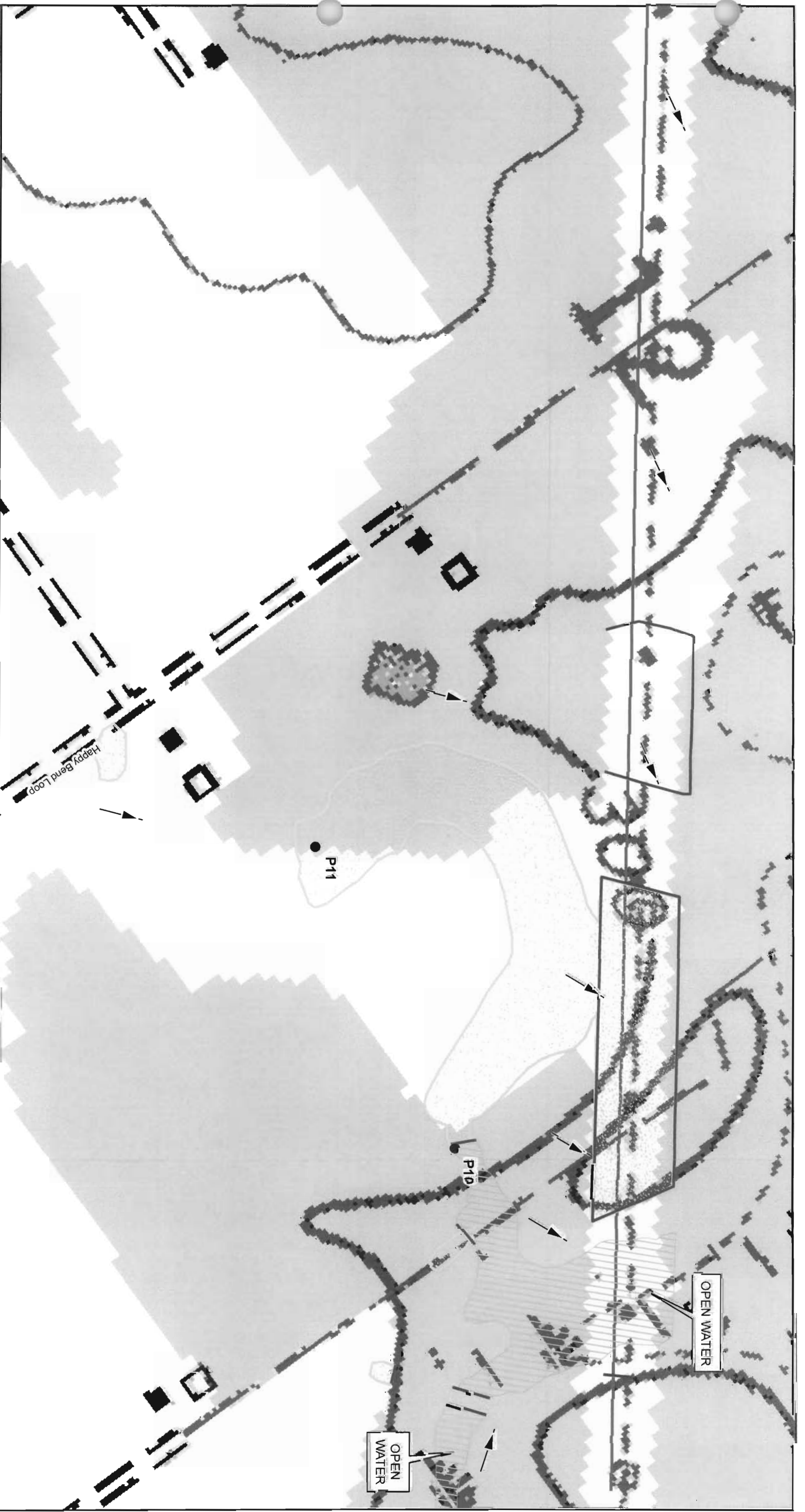

\* Note: Entire 150' ROW should be seeded with fescue/rye/bermuda grass mixture.

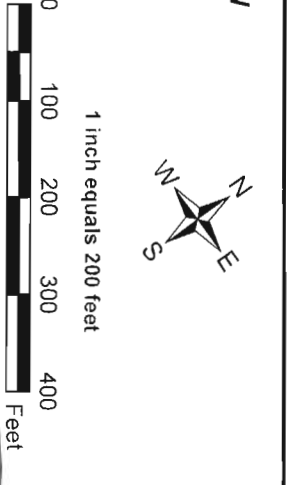

- SHEET 1 OF 3
- Photo location
  - Straw/Hay bales
  - ▨ Area seeded and covered with straw
  - Transmission line
  - ▨ Wetland area
  - Drainage pattern

**PBSJ**

APPENDIX B2  
SITE MAP  
PLEASANT HILLS TO ANO EMERGENCY REBUILD  
ENTERGY SERVICES, INC.  
POPE COUNTY, ARKANSAS

PROJECT NO. 100001086  
DATE: 04/22/08

Base Map: USGS 7.5' Topographic Maps, Hartsville & Moreland

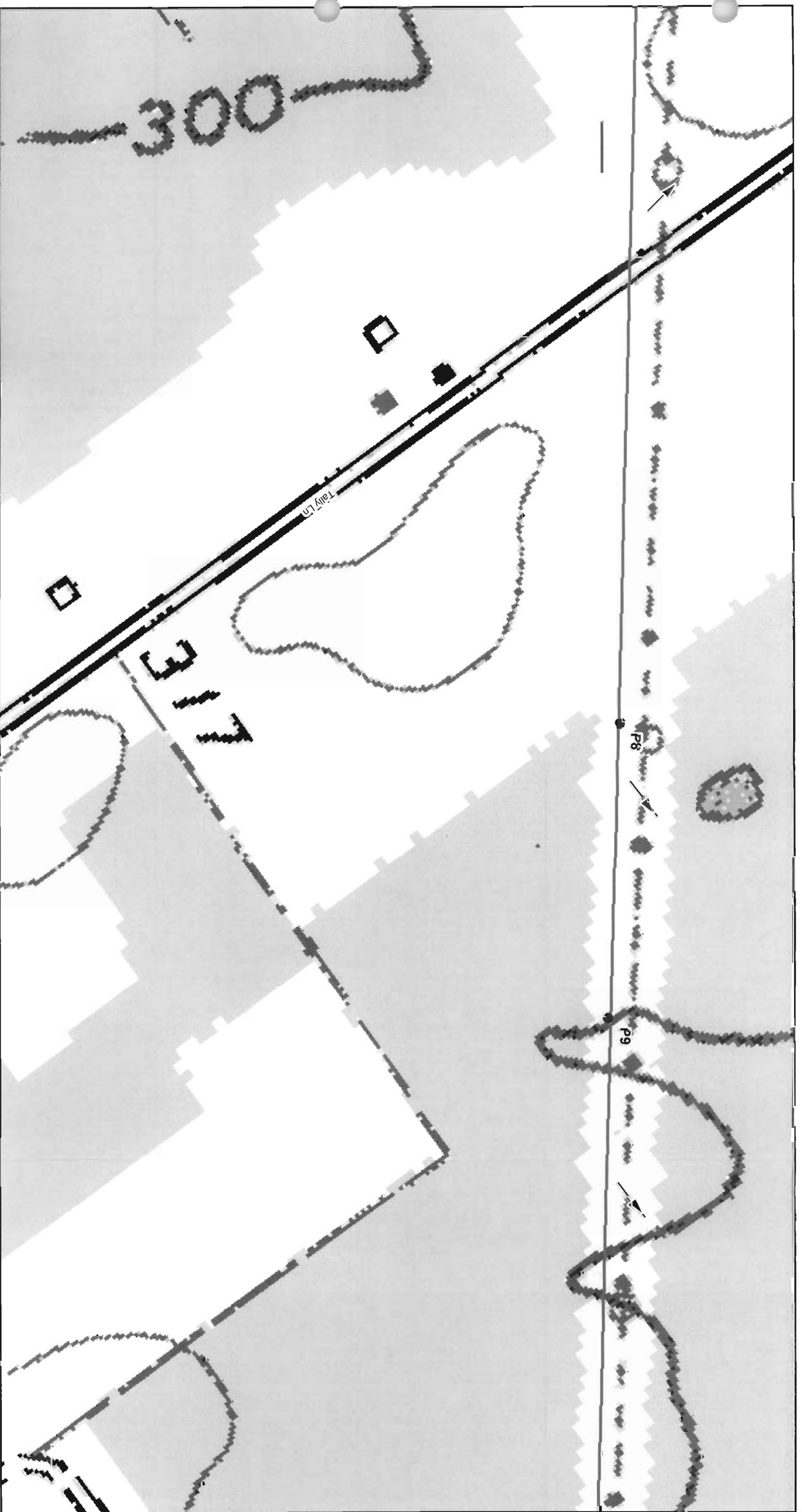

\* Note: Entire 150' ROW should be seeded with fescue/rye/bermuda grass mixture.

1 inch equals 200 feet



- |                                      |                     |
|--------------------------------------|---------------------|
| ● Photo location                     | — Transmission line |
| — Straw/Hay bales                    | ▨ Wetland area      |
| ▨ Area seeded and covered with straw | → Drainage pattern  |

SHEET 2 OF 3



APPENDIX B2

SITE MAP  
 PLEASANT HILLS TO AND EMERGENCY REBUILD  
 ENERGY SERVICES, INC.  
 POPE COUNTY, ARKANSAS

Base Map: USGS 7.5' Topographic Maps, Hattiesville & Moreland

PROJECT NO. 100001086

DATE: 04/22/08

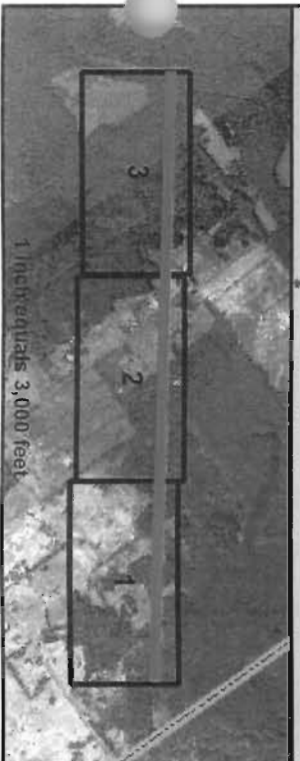

1 inch equals 3,000 feet

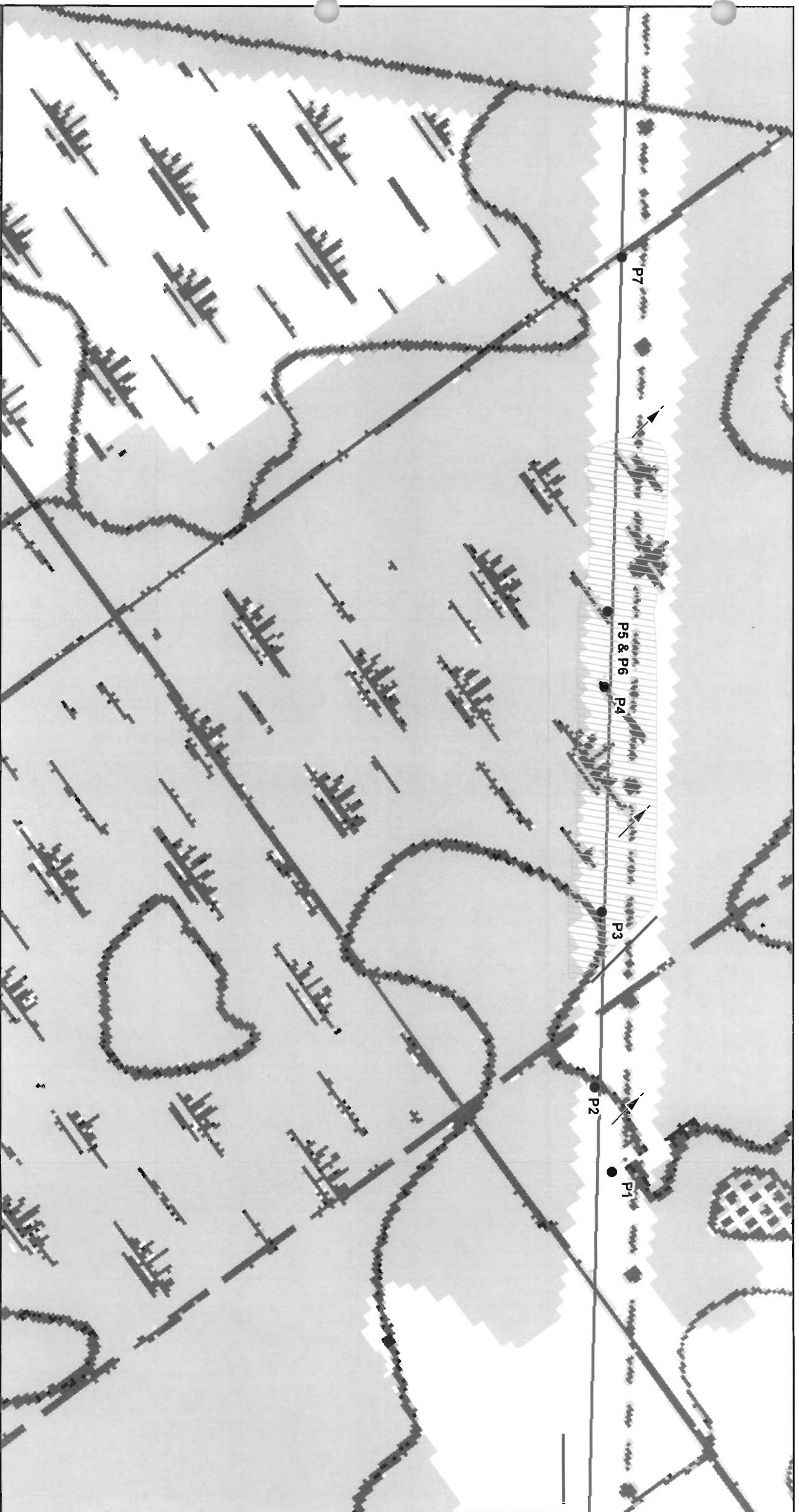

\* Note: Entire 150' ROW should be seeded with fescue/rye/bermuda grass mixture.



1 inch equals 200 feet



- |                                      |                     |
|--------------------------------------|---------------------|
| ● Photo location                     | — Transmission line |
| — Straw/Hay bales                    | ▨ Wetland area      |
| ▨ Area seeded and covered with straw | → Drainage pattern  |

SHEET 3 OF 3



APPENDIX B2  
SITE MAP

PLEASANT HILLS TO ANO EMERGENCY REBUILD  
ENERGY SERVICES, INC.  
POPE COUNTY, ARKANSAS

Base Map: USGS 7.5' Topographic Maps, Hatfieldville & Moreland

PROJECT NO. 100001086

DATE: 04/22/08

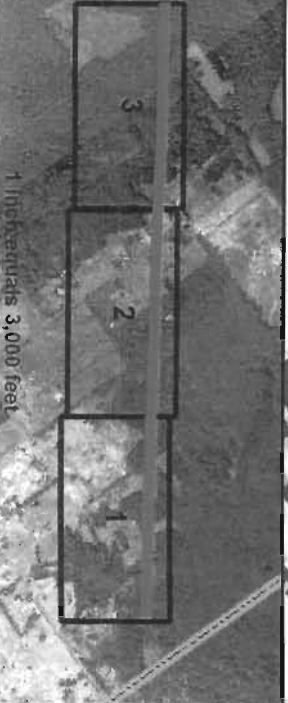

1 inch equals 3,000 feet



## **Appendix C**

### **Inspection Report Forms**

**STORMWATER POLLUTION PREVENTION PLAN  
INSPECTION AND MAINTENANCE REPORT FORM**

| General Information   |   |                                   |  |
|---|---|-----------------------------------|--|
| <b>Project Name</b>   | Pleasant Hills to ANO Emergency Rebuild |                                   |  |
| <b>NPDES Tracking No.</b>   |   | <b>Location</b>                   |  |
| <b>Date of Inspection</b>   |   | <b>Start/End Time</b>             |  |
| <b>Inspector's Name(s)</b>  |   |                                   |  |
| <b>Inspector's Title(s)</b>   |   |                                   |  |
| <b>Inspector's Contact Information</b>  |   |                                   |  |
| <b>Describe present phase of construction</b>   |   |                                   |  |
| <b>Type of Inspection</b>   |   |                                   |  |
| <input type="checkbox"/> Regular <input type="checkbox"/> Pre-storm event <input type="checkbox"/> During storm event <input type="checkbox"/> Post-storm event |   |                                   |  |
| Weather Information   |   |                                   |  |
| <b>Has it rained since the last inspection?</b>   |   |                                   |  |
| <input type="checkbox"/> Yes <input type="checkbox"/> No  |   |                                   |  |
| <b>If yes, provide:</b>   |   |                                   |  |
| <b>Storm Start Date &amp; Time:</b>   | <b>Storm Duration (hrs):</b>            | <b>Approximate Rainfall (in):</b> |  |
|   |   |                                   |  |
| <b>Weather at time of this inspection?</b>  |   |                                   |  |
|   |   |                                   |  |
| <b>Do you suspect that discharges may have occurred since the last inspection?</b>  |   |                                   |  |
| <input type="checkbox"/> Yes <input type="checkbox"/> No  |   |                                   |  |
| <b>Are there any discharges at the time of inspection?</b>  |   |                                   |  |
| <input type="checkbox"/> Yes <input type="checkbox"/> No  |   |                                   |  |

"I certify under penalty of law that I am knowledgeable in the principals of erosion and sediment control, possessing the skills to evaluate conditions at the above construction site that could impact stormwater quality, and knowledgeable in the correct installation of erosion and sediment controls. I am able to assess the effectiveness of any sediment and erosion control measures selected in the SWPPP to control the quality of stormwater discharges from the above construction site. Additionally, I certify that I have reviewed the Arkansas Stormwater Construction General Permit ARR150000 and SWPPP which was prepared by the owner of this site."

\_\_\_\_\_  
Signature

\_\_\_\_\_  
Date

STORMWATER POLLUTION PREVENTION PLAN  
INSPECTION AND MAINTENANCE REPORT FORM

\_\_\_\_\_ Date \_\_\_\_\_

**Location of Controls:** \_\_\_\_\_

Control Feature: \_\_\_\_\_  
\_\_\_\_\_  
\_\_\_\_\_

Control Condition: \_\_\_\_\_  
\_\_\_\_\_  
\_\_\_\_\_

Maintenance Required: \_\_\_\_\_  
\_\_\_\_\_  
\_\_\_\_\_

**Location of Controls:** \_\_\_\_\_

Control Feature: \_\_\_\_\_  
\_\_\_\_\_  
\_\_\_\_\_

Control Condition: \_\_\_\_\_  
\_\_\_\_\_  
\_\_\_\_\_

Maintenance Required: \_\_\_\_\_  
\_\_\_\_\_  
\_\_\_\_\_

**Location of Controls:** \_\_\_\_\_

Control Feature: \_\_\_\_\_  
\_\_\_\_\_  
\_\_\_\_\_

Control Condition: \_\_\_\_\_  
\_\_\_\_\_  
\_\_\_\_\_

Maintenance Required: \_\_\_\_\_  
\_\_\_\_\_  
\_\_\_\_\_

**Appendix D**

**Erosion and Sediment Control Measures Construction Specifications**



**ENTERGY TRANSMISSION STANDARDS  
ENVIRONMENT AND VEGETATION  
CONSTRUCTION**

|  |  |                               |
|--|--|-------------------------------|
| <b>Title:</b> Erosion and Sediment Control Measures Construction Specification | <b>Standard No.:</b> ES0101, Rev. 00                                     | <b>Effective Date:</b> Dec-04 |
| <b>Prepared By:</b><br>H. Steve Kimbrough                                      | <b>Approved By:</b><br>Ronald L. Rowland<br>Manager, Transmission Design |                               |

**Table of Contents**

|      |   |    |
|------|---|----|
| 1.0  | Introduction .....                      | 3  |
| 1.1  | Purpose .....                           | 3  |
| 1.2  | Scope .....                             | 3  |
| 2.0  | Definitions.....                        | 3  |
| 3.0  | Reference Standards .....               | 3  |
| 3.1  | Industry Standards.....                 | 3  |
| 3.2  | Transmission Line Standards .....       | 4  |
| 3.3  | Substation Standards .....              | 4  |
| 3.4  | Drawings .....                          | 4  |
| 4.0  | Safety .....                            | 4  |
| 5.0  | General.....                            | 5  |
| 5.1  | Technical Terms and Conditions.....     | 5  |
| 6.0  | Products.....                           | 8  |
| 6.1  | Filter Fabric.....                      | 8  |
| 6.2  | Silt Fence Stakes and Posts .....       | 9  |
| 6.3  | Straw Bales.....                        | 9  |
| 6.4  | Temporary Erosion Control Matting ..... | 9  |
| 6.5  | Rock Check Dams.....                    | 10 |
| 6.6  | Sandbag Check Dams .....                | 10 |
| 6.7  | Slope Drains .....                      | 10 |
| 6.8  | Riprap.....                             | 10 |
| 6.9  | Geotextile for Riprap Underlayment..... | 11 |
| 6.10 | Strings.....                            | 11 |
| 6.11 | Tie Wire .....                          | 11 |

| Rev. No | Revisions            | Date   | Rev. by | App. by |
|---------|----------------------|--------|---------|---------|
| 0       | New issue / Original | Dec-04 | HSK     | RLR     |
|         |                      |        |         |         |
|         |                      |        |         |         |

This document is the property of Entergy Services, Inc. and contains confidential and proprietary information owned by Entergy Services, Inc. Any copying, use, or disclosure of this information without the written permission of Entergy Services, Inc. is strictly prohibited. This material is protected under trade secret and unfair competition laws and the expression of the information contained herein is protected under Federal copyright laws. Violations thereof may result in criminal penalties and fines.

Copyright Unpublished Work Entergy Services, Inc.  
All Rights Reserved

|  |                                      |                               |
|--|--------------------------------------|-------------------------------|
| Title: <b>Erosion and Sediment Control Measures Construction Specification</b> | Standard No.: <b>ES0101, Rev. 00</b> | Effective Date: <b>Dec-04</b> |
|--|--------------------------------------|-------------------------------|

|      |                                    |    |
|------|------------------------------------|----|
| 7.0  | Installation .....                 | 11 |
| 7.1  | Silt Fences .....                  | 11 |
| 7.2  | Straw Bales.....                   | 11 |
| 7.3  | Erosion Control Matting .....      | 11 |
| 7.4  | Rock Check Dams .....              | 12 |
| 7.5  | Baled Straw Check Dams .....       | 12 |
| 7.6  | Sandbag Check Dams .....           | 12 |
| 7.7  | Slope Drains .....                 | 12 |
| 7.8  | Diversion Ditches .....            | 13 |
| 7.9  | Sediment Basins .....              | 13 |
| 7.10 | Dumped Riprap .....                | 13 |
| 7.11 | Sediment Removal and Disposal..... | 13 |
| 8.0  | Inspections .....                  | 14 |
| 8.1  | General.....                       | 14 |
| 8.2  | Inspections Details .....          | 14 |
| 8.3  | Inspection Reports.....            | 14 |
| 9.0  | Not Used .....                     | 14 |
| 10.0 | Not Used .....                     | 14 |
| 11.0 | Responsibilities.....              | 14 |
| 11.1 | Interpretation .....               | 14 |
| 11.2 | Deviation .....                    | 14 |
| 12.0 | Acknowledgments .....              | 15 |
| 13.0 | Attachments.....                   | 15 |

This document is the property of Entergy Services, Inc. and contains confidential and proprietary information owned by Entergy Services, Inc. Any copying, use, or disclosure of this information without the written permission of Entergy Services, Inc. is strictly prohibited. This material is protected under trade secret and unfair competition laws and the expression of the information contained herein is protected under Federal copyright laws. Violations thereof may result in criminal penalties and fines.

Copyright Unpublished Work Entergy Services, Inc.  
All Rights Reserved

|  |                                      |                               |
|--|--------------------------------------|-------------------------------|
| Title: <b>Erosion and Sediment Control Measures Construction Specification</b> | Standard No.: <b>ES0101, Rev. 00</b> | Effective Date: <b>Dec-04</b> |
|--|--------------------------------------|-------------------------------|

## 1.0 Introduction

### 1.1 Purpose

The purpose of this specification is to provide contractors with requirements in addition to those of the contract task order or stand-alone contract. These specifications are intended to provide contractors and company crews with Entergy's minimum technical requirements for the installation of erosion and sediment control measures on all transmission lines (69 kV and above) and on all substations. The standard is worded to be used as either instructions for Entergy personnel or as a part of a contract. Where the standard is to become a part of a contract, the other components of the contract shall be prepared in accordance with the **Transmission Line** or **Substation** guidelines for preparation of construction packages. Where this specification conflicts with drawings, this written specification has superiority.

### 1.2 Scope

**1.2.1** These specifications apply to both Transmission Line projects and Substation projects for the installation of all erosion and sedimentation control measures, usually as part of site preparation or a part of the Storm Water Pollution Prevention Plan.

**1.2.2** The accompanying design drawings and the "Request for Proposal" will indicate the type of control measures to be used.

## 2.0 Definitions

Entergy Engineer - Shall represent the Entergy employee who has responsibility for the project construction. The Entergy engineer may delegate some responsibilities to the project inspector, when appropriate.

Entergy - Also called Owner in some contract documents. Shall represent the appropriate Entergy Operating Company. See the General Services Agreement or Stand-Alone Contract to be signed by a duly authorized representative of Entergy and the Contractor.

Contractor - Shall represent the General Contractor and all subcontractors contracted for work on the project. See the above mentioned General Services Agreement or Stand-Alone Contract. This term shall also refer to Entergy construction crews when work is being performed in house.

## 3.0 Reference Standards

### 3.1 Industry Standards.

The publications listed below form a part of this specification to the extent referenced. The publications are referred to in the text by basic designation only.

#### AMERICAN SOCIETY FOR TESTING AND MATERIALS (ASTM)

This document is the property of Entergy Services, Inc. and contains confidential and proprietary information owned by Entergy Services, Inc. Any copying, use, or disclosure of this information without the written permission of Entergy Services, Inc. is strictly prohibited. This material is protected under trade secret and unfair competition laws and the expression of the information contained herein is protected under Federal copyright laws. Violations thereof may result in criminal penalties and fines.

Copyright Unpublished Work Entergy Services, Inc.  
All Rights Reserved

|  |                                      |                               |
|--|--------------------------------------|-------------------------------|
| Title: <b>Erosion and Sediment Control Measures Construction Specification</b> | Standard No.: <b>ES0101, Rev. 00</b> | Effective Date: <b>Dec-04</b> |
|--|--------------------------------------|-------------------------------|

- ASTM D 4439 (1997) Standard Terminology for Geosynthetics
- ASTM D 4491 (1996) Water Permeability of Geotextiles by Permittivity
- ASTM D 4533 (1991; R 1996) Trapezoid Tearing Strength of Geotextiles
- ASTM D 4632 (1991; R 1996) Grab Breaking Load and Elongation of Geotextiles
- ASTM D 4751 (1995) Determining Apparent Opening Size of a Geotextile
- ASTM D 4873 (1995) Identification, Storage, and Handling of Geosynthetic Rolls

UFGS-01356 (August 1996) U. S. Army Corps of Engineers, Uniform Facilities Guide Specifications 01356A, (Replacing CEGS of same number)

### 3.2 Transmission Line Standards

Refer to construction specifications numbered in the TO01—series. Construction packages for each project will contain copies and an index of all applicable specifications. TO0102, Technical Guidelines for Construction Specifications, should be part of every stand-alone contract or General Services Agreement.

### 3.3 Substation Standards

Refer to other substation contract documents and drawings in the construction package.

### 3.4 Drawings

| ESI Dwg. No. | Title                          |
|--------------|--------------------------------|
| TNSW01A0     | Straw Bale Check Dam           |
| TNSW02A0     | Slope Installation             |
| TNSW03A0     | Dissipator                     |
| TNSW04A0     | Riprap Slope Protection        |
| TNSW05A0     | Rock Check Dam                 |
| TNSW06A0     | Straw Bale Dike                |
| TNSW07A0     | Silt Fence                     |
| TNSW08A0     | Temporary Diversion Dike       |
| TNSW09A0     | Typical Stream Crossing        |
| TNSW10A0     | Typical Cross Slope Protection |
| TNSW11A0     | Typical Down-Slope Protection  |
| TNSW12A0     | Typical Wet Weather Conveyance |
| TNSW13A0     | Rolling Dip and Waterbar       |

### 4.0 Safety

Workers shall have a weekly safety briefing to caution them of working around energized

This document is the property of Entergy Services, Inc. and contains confidential and proprietary information owned by Entergy Services, Inc. Any copying, use, or disclosure of this information without the written permission of Entergy Services, Inc. is strictly prohibited. This material is protected under trade secret and unfair competition laws and the expression of the information contained herein is protected under Federal copyright laws. Violations thereof may result in criminal penalties and fines.

Copyright Unpublished Work Entergy Services, Inc  
All Rights Reserved

|  |   |                                  |
|--|---|----------------------------------|
| Title: <b>Erosion and Sediment Control Measures Construction Specification</b> | Standard No.:<br><b>ES0101, Rev. 00</b> | Effective Date:<br><b>Dec-04</b> |
|--|---|----------------------------------|

facilities, operating equipment on steep slopes and near facilities that might be damaged (guys, anchors, towers, poles, underground utilities, etc.). Workers entering Entergy Substations must notify the Entergy dispatcher when they enter and leave unless other workers have already made notification. Workers must wear personal protective gear while on Entergy right of ways and properties. If the Contractor does not have a published safety manual, his workers must comply with the Entergy Safety Manual.

## 5.0 General

Extracts of Corps of Engineer Unified Facilities Guide Specification UFGS-01356A, dated August 1996, are incorporated in this standard and represent the Entergy standard for installation for erosion and control measures. Corrections and revisions to the extracts and paragraph numbering was changed to conform to Entergy standard practices. The term "Owner" has been replaced with "Entergy".

## 5.1 Technical Terms and Conditions

The Contractor shall implement the storm water pollution prevention measures specified in this section in a manner which will meet the requirements of the Stormwater Pollution Prevention Plan (SWPPP) and the National Pollution Discharge Elimination System (NPDES) permit issued by the state in which the project is located. Any control measure that the Contractor recognizes a need for, that is not described in the SWPPP, shall be brought to the attention of the Entergy Engineer for consideration and approval before doing any construction on said control measure. Some control measures are inappropriate in some cases and may need confirmation from the consulting expert that prepared the SWPPP. Subject to the General Services Agreement or Stand-Alone Contract and any approved Change orders, the precedence of Control Measures documents is as follows:

- a) National Pollution Discharge Elimination System.
- b) Stormwater Pollution Prevention Plan.
- c) This written specification.
- d) The attached drawings.

### 5.1.1 Submittals

Entergy approval is required for submittals. The following shall be submitted for approval:

- a) Mill Certificates or Affidavits for geotextiles.

### 5.1.2 Stabilization Practices

The stabilization practices to be implemented shall include temporary seeding, mulching, geotextiles, sod stabilization, vegetative buffer strips, erosion control mats, protection of trees, preservation of mature vegetation, etc., as indicated in the SWPPP or as directed by Entergy. The Contractor shall record and report the dates when the major grading activities occur, (e.g., clearing and grubbing, excavation, embankment, and grading); when construction activities temporarily or permanently cease on a portion of the site; and when stabilization practices are initiated. Except as provided in paragraphs 5.1.2.1 (Unsuitable Conditions) and 5.1.2.2 (No Activity for Less Than 21 Days), stabilization practices shall be initiated as soon as practicable,

This document is the property of Entergy Services, Inc. and contains confidential and proprietary information owned by Entergy Services, Inc. Any copying, use, or disclosure of this information without the written permission of Entergy Services, Inc. is strictly prohibited. This material is protected under trade secret and unfair competition laws and the expression of the information contained herein is protected under Federal copyright laws. Violations thereof may result in criminal penalties and fines.

|  |   |                                  |
|--|---|----------------------------------|
| Title: <b>Erosion and Sediment Control Measures Construction Specification</b> | Standard No.:<br><b>ES0101, Rev. 00</b> | Effective Date:<br><b>Dec-04</b> |
|--|---|----------------------------------|

but no more than 14 days later, in any portion of the site where construction activities have temporarily or permanently ceased.

**5.1.2.1 Unsuitable Conditions**

Where the initiation of stabilization measures, by the fourteenth day after construction activity temporarily or permanently ceases, is precluded by unsuitable conditions caused by the weather, stabilization practices shall be initiated as soon as practicable after conditions become suitable.

**5.1.2.2 No Activity for Less Than 21 Days**

Where construction activity will resume on a portion of the site within 21 days from when activities ceased (e.g., the total time period that construction activity is temporarily ceased is less than 21 days), then stabilization practices do not have to be initiated on that portion of the site by the fourteenth day after construction activity temporarily ceased.

**5.1.3 Structural Practices**

The SWPPP requirements for sediment traps, silt fences, or equivalent sediment controls for all sideslope and downslope boundaries of the construction area may provide for an alternative consisting of a sediment basin providing storage for a predetermined capacity, depending upon the size of the site. Structural practices shall be implemented to divert flows from exposed soils, temporarily store flows, or otherwise limit runoff and the discharge of pollutants from exposed areas of the site. Structural practices shall be implemented in a timely manner during the construction process to minimize erosion and sediment runoff. Structural practices shall include the following devices. Location and details of installation and construction are shown on the drawings included in the SWPPP. Additional practices shall be implemented as required by field observation to prevent erosion and off-site transport of sediments.

**5.1.3.1 Silt Fences**

This item consists of placing and securing a geotextile fabric to an existing support system or constructing a self-supporting geotextile fence where shown on the plans or as directed by Entergy for the purposes of impeding the flow of water carrying silt toward existing streams and/or across adjacent property; redirecting the flow of silt laden water to a sediment basin; and/or routing clean water through the construction area. The Contractor shall provide silt fences as a temporary structural practice to minimize erosion and sediment runoff. Silt fences shall be properly installed to effectively retain sediment before or immediately after completing each phase of work (e.g. clearing and grubbing, excavation, embankment, and grading) where erosion would occur in the form of sheet and rill erosion. Silt fences shall also be installed around spoil piles, haul routes and staging areas as required to prevent erosion and sediment transport from the site. Silt fences shall be installed in the locations indicated on the drawings and additionally as required by field observations. Final removal of silt fence barriers shall be upon approval by Entergy. Generally, installation may be at the following locations:

- a. Along the downhill perimeter edge of all areas disturbed.

This document is the property of Entergy Services, Inc. and contains confidential and proprietary information owned by Entergy Services, Inc. Any copying, use, or disclosure of this information without the written permission of Entergy Services, Inc. is strictly prohibited. This material is protected under trade secret and unfair competition laws and the expression of the information contained herein is protected under Federal copyright laws. Violations thereof may result in criminal penalties and fines.

|  |   |                                  |
|--|---|----------------------------------|
| Title: <b>Erosion and Sediment Control Measures Construction Specification</b> | Standard No.:<br><b>ES0101, Rev. 00</b> | Effective Date:<br><b>Dec-04</b> |
|--|---|----------------------------------|

- b. Along the top of the slope or top bank of drainage ditches, channels, swales, etc., that traverse disturbed areas.
- c. Along the toe of all cut slopes and fill slopes of the construction areas.  
Across disturbed slopes. Rows shall be spaced as required in the SWPPP drawings, details and text. Silt fence shall not be installed in or below slopes greater than 6:1 without wire mesh support nor within channels or conveyances.

### 5.1.3.2 Straw Bales

The Contractor shall provide bales of straw as a temporary structural practice to minimize erosion and sediment runoff as indicated. Typical uses of straw bales include, but is not limited to, straw bale dikes (on slopes) and straw bale check dams (in drainage channels) as described in the SWPPP details and text. Bales shall be properly placed to effectively retain sediment immediately after completing each phase of work (e.g., clearing and grubbing, excavation, embankment, and grading) in each independent runoff area (e.g., after clearing and grubbing in a area between a ridge and drain, bales shall be placed as work progresses, bales shall be removed/replaced/relocated as needed for work to progress in the drainage area). Areas where straw bales are to be used are shown on the drawings or described in the SWPPP. Final removal of straw bale barriers shall be upon approval by Entergy. Rows of bales of straw shall generally be provided as follows unless directed otherwise by Entergy:

- a. Along the downhill perimeter edge of areas disturbed.
- b. Along the top of the slope or top bank of drainage ditches, channels, swales, etc., that traverse disturbed areas.
- c. Along the toe of cut slopes and fill slopes of the construction areas.
- d. Perpendicular to the flow in the bottom of existing drainage ditches, channels, swales, etc., that traverse disturbed areas or carry runoff from disturbed areas. Rows shall be spaced as required in the SWPPP drawings, details, and text.
- e. Perpendicular to the flow in the bottom of new drainage ditches, channels, and swales. Rows shall be spaced as required in the SWPPP drawings, details and text.
- f. At the entrance to culverts that receive runoff from disturbed areas.

### 5.1.3.3 Diversion Dikes

Diversion dikes shall have a maximum channel slope of 2 percent and shall be adequately compacted to prevent failure. The minimum height measured from the top of the dike to the bottom of the channel shall be 18 inches. The minimum base width shall be 6 feet and the minimum top width shall be 2 feet. The Contractor shall ensure that the diversion dikes are not damaged by construction operations or traffic. Diversion dikes shall be located as required by the SWPPP drawings, details, and text.

This document is the property of Entergy Services, Inc. and contains confidential and proprietary information owned by Entergy Services, Inc. Any copying, use, or disclosure of this information without the written permission of Entergy Services, Inc. is strictly prohibited. This material is protected under trade secret and unfair competition laws and the expression of the information contained herein is protected under Federal copyright laws. Violations thereof may result in criminal penalties and fines.

Copyright Unpublished Work Entergy Services, Inc  
All Rights Reserved

|  |   |                                  |
|--|---|----------------------------------|
| Title: <b>Erosion and Sediment Control Measures Construction Specification</b> | Standard No.:<br><b>ES0101, Rev. 00</b> | Effective Date:<br><b>Dec-04</b> |
|--|---|----------------------------------|

**5.1.3.4 Diversion Ditch**

Where shown on the plans or as directed by Entergy, this item shall consist of excavation or grading for diversion ditches to control soil erosion at selected locations. Diversion ditches will generally be excavated above the backslopes of cuts, along the top of embankments, or across foreslopes and backslopes to divert the run-off to natural drainage channels, downslope protection locations, or sediment basins. Sediment laden water shall not be discharged directly into natural drainage channels.

**5.1.3.5 Erosion Control Matting**

This item shall consist of the placement of temporary and permanent erosion control matting at locations shown on the plans or as directed by Entergy. It will generally be used in diversion ditches and at the ends of berms, or at other location where the flow of water is concentrated. Areas receiving matting shall be shaped, limed, fertilized and seeded, when required, before placement of the matting.

**5.1.3.6 Baled Straw Check Dams**

This item shall consist of preparing and placing baled straw in ditches to impede run-off velocity of water and to prevent scouring and eroding of soil. Check dams shall be constructed at the locations shown on the plans or as directed by Entergy.

**5.1.3.7 Rock Check Dams**

This item shall consist of constructing small dams across swales or ditches to slow concentrated storm water runoff to a non-erosive velocity. Rock check dams shall be constructed at locations shown on the plans or as directed by Entergy.

**5.1.3.8 Sandbag Check Dams**

Where shown on the plans or as directed by the Engineer, this item shall consist of preparing and placing sandbags in ditches to impede run-off velocity of water and to prevent scouring and eroding of soil until permanent erosion control items can be placed.

**5.1.3.9 Sediment Basin**

This item shall consist of excavating and grading a storage area to detain sediment-laden runoff from disturbed areas long enough to allow sediment to settle out. Sediment basins shall be placed at locations shown on the plans or as directed by the Engineer.

**5.1.3.10 Dumped Riprap**

This item shall consist of a protective layer of riprap of the type specified, placed according to these specifications, to the line, grade, thickness and location shown on the plans or as directed by the Engineer.

**6.0 Products**

**6.1 Filter Fabric**

The geotextile shall comply with the requirements of ASTM D 4439 and shall consist of polymeric filaments which are formed into a stable network such that filaments retain their

This document is the property of Entergy Services, Inc. and contains confidential and proprietary information owned by Entergy Services, Inc. Any copying, use, or disclosure of this information without the written permission of Entergy Services, Inc. is strictly prohibited. This material is protected under trade secret and unfair competition laws and the expression of the information contained herein is protected under Federal copyright laws. Violations thereof may result in criminal penalties and fines.

|  |                                      |                               |
|--|--------------------------------------|-------------------------------|
| Title: <b>Erosion and Sediment Control Measures Construction Specification</b> | Standard No.: <b>ES0101, Rev. 00</b> | Effective Date: <b>Dec-04</b> |
|--|--------------------------------------|-------------------------------|

relative positions. The filament shall consist of a long-chain synthetic polymer composed of at least 85 percent by weight of ester, propylene, or amide, and shall contain stabilizers and/or inhibitors added to the base plastic to make the filaments resistant to deterioration due to ultraviolet and heat exposure. Synthetic filter fabric shall contain ultraviolet ray inhibitors and stabilizers to provide a minimum of six months of expected usable construction life at a temperature range of 0 to 120 degrees F. A mill certificate or affidavit shall be provided attesting that the fabric and factory seams meet chemical, physical, and manufacturing requirements specified above. The mill certificate or affidavit shall specify the actual Minimum Average Roll Values and shall identify the fabric supplied by roll identification numbers. The Contractor shall submit a mill certificate or affidavit signed by a legally authorized official from the company manufacturing the filter fabric. Filter fabric shall be identified, stored and handled in accordance with ASTM D 4873. The filter fabric shall meet the following requirements:

| FILTER FABRIC FOR SILT SCREEN FENCE |                |                         |
|-------------------------------------|----------------|-------------------------|
| PHYSICAL PROPERTY                   | TEST PROCEDURE | STRENGTH REQUIREMENT    |
| Grab Tensile Elongation (%)         | ASTM D 4632    | 100 lbs. min. 30 % max. |
| Trapezoid Tear                      | ASTM D 4533    | 55 lbs. min.            |
| Permittivity                        | ASTM D 4491    | 0.2 sec-1               |
| AOS (U.S. Std Sieve)                | ASTM D 4751    | 20-100                  |

**6.2 Silt Fence Stakes and Posts**

The Contractor may use either wooden stakes or steel posts for fence construction. Wooden stakes utilized for silt fence construction shall have a minimum cross section of 2 inches by 2 inches. Steel posts (standard "U" or "T" section) utilized for silt fence construction shall have a minimum weight of 1.33 pounds per linear foot.

**6.3 Straw Bales**

The straw in the bales shall be stalks from oats, wheat, rye, barley, rice or from grasses such as bahiagrass, bermuda, etc., furnished in air dry condition. The bales shall have a standard cross section of 14 inches by 18 inches. All bales shall be string-tied. The Contractor shall use wooden stakes to secure the straw bales to the ground. Wooden stakes utilized for this purpose, shall have minimum dimensions of 2 inches x 2 inches in cross section and shall have a minimum length of 3 feet. Steel posts (standard "U" or "T" section) having a minimum weight of 1.33 pounds per linear foot or steel rebar having a minimum diameter of 5/8" may be used in lieu of wooden posts, with prior approval of Entergy.

**6.4 Temporary Erosion Control Matting**

**6.4.1** The matting shall be as shown on the plans and/or as specified in the project specifications. The type of matting used in a particular area shall be at the option of the Contractor, except as specified in the SWPPP or otherwise directed by Entergy.

**6.4.2** The matting shall be provided as follows, unless approved otherwise by Entergy:

This document is the property of Entergy Services, Inc. and contains confidential and proprietary information owned by Entergy Services, Inc. Any copying, use, or disclosure of this information without the written permission of Entergy Services, Inc. is strictly prohibited. This material is protected under trade secret and unfair competition laws and the expression of the information contained herein is protected under Federal copyright laws. Violations thereof may result in criminal penalties and fines.

|  |   |                                  |
|--|---|----------------------------------|
| Title: <b>Erosion and Sediment Control Measures Construction Specification</b> | Standard No.:<br><b>ES0101, Rev. 00</b> | Effective Date:<br><b>Dec-04</b> |
|--|---|----------------------------------|

- a. Straw matting with single netting shall be Contech Ero-Mat, North American Green S75, or American Excelsior Company Premier Straw Blanket (single net).
- b. Straw matting with double netting shall be Contech High Velocity Ero-Mat, North American Green S150, or American Excelsior Company Premier Straw Blanket (double netting).
- c. Wood excelsior matting with single netting shall be American Excelsior Curlex I or Contech Standard Excelsior Matting.
- d. Wood Excelsior matting with double netting shall be American Excelsior Curlex II or Contech Standard Plus Excelsior Matting.
- e. Non-organic open weave temporary erosion control matting shall be Contech C-Jute or approved alternate.

### **6.5 Rock Check Dams**

Rock for rock check dams shall be hard, durable, crushed stone aggregate as manufactured by local quarries ranging in size from 1-1/2" minimum to 6" maximum. It shall not contain more than 5% by weight of shale, slate, or other deleterious matter. The stone shall be uniformly graded and the amount passing the #200 sieve shall be not more than 10% by weight. Rock having a different gradation may be used when determined by Entergy to be suitable for the purpose intended.

### **6.6 Sandbag Check Dams**

Sand for sandbags shall consist of a sandy type soil or clean sand that meets the approval of Entergy. Bags for sand shall be of tightly woven burlap or other material that is sufficiently durable to remain intact for the time intended.

### **6.7 Slope Drains**

Pipe for slope drains shall have a 12" minimum diameter and shall comply with Type C corrugated polyethylene pipe complying with AASHTO M 294. Polyethylene pipe shall have a corrugated outer shell with an essentially smooth wall waterway. Couplings and fittings or recommended by the pipe manufacturer shall be used. Used pipe meeting these requirements may be used when determined by Entergy to be suitable for the purpose intended.

### **6.8 Riprap**

**6.8.1** Dumped riprap shall be reasonably free of fines and reasonably well graded between the maximum and minimum rock sizes so as to produce a minimum of voids. In general, the maximum piece size shall not be greater than 18" in any dimension and approximately 50% of the material shall consist of pieces weighing 35 pounds or more.

**6.8.2** Broken concrete conforming to the above requirements may be used in lieu of dumped riprap when specified on the plans or approved by Entergy. Broken concrete shall be free of protrusions of reinforcing steel.

This document is the property of Entergy Services, Inc. and contains confidential and proprietary information owned by Entergy Services, Inc. Any copying, use, or disclosure of this information without the written permission of Entergy Services, Inc. is strictly prohibited. This material is protected under trade secret and unfair competition laws and the expression of the information contained herein is protected under Federal copyright laws. Violations thereof may result in criminal penalties and fines.

Copyright Unpublished Work Entergy Services, Inc.  
All Rights Reserved

|  |                                      |                               |
|--|--------------------------------------|-------------------------------|
| Title: <b>Erosion and Sediment Control Measures Construction Specification</b> | Standard No.: <b>ES0101, Rev. 00</b> | Effective Date: <b>Dec-04</b> |
|--|--------------------------------------|-------------------------------|

### 6.9 Geotextile for Riprap Underlayment

A synthetic fiber geotextile fabric shall be used as a filter blanket under dumped riprap. Fabric shall be Contech C80NW or approved equal.

### 6.10 Strings

All strings on bales of straw and hay and all string used for holding mats or mulch in place shall be of synthetic fibers that will endure at least 18 months of ultraviolet radiation before breaking down.

### 6.11 Tie Wire

Any tie wire used in construction of the control measures shall be soft drawn iron wire with no protective coating, so as to allow rapid deterioration.

## 7.0 Installation

### 7.1 Silt Fences

Silt fences shall be placed on contour. Silt fences shall extend a minimum of 16 inches above the ground surface and shall not exceed 34 inches above the ground surface. Filter fabric shall be from a continuous roll cut to the length of the barrier to avoid the use of joints. When joints are unavoidable, filter fabric shall be spliced together at a support post with a minimum 6-inch overlap and securely sealed. A trench shall be excavated approximately 4 inches wide and 6 inches deep on the upslope side of the location of the silt fence. The 4-inch by 6-inch trench shall be backfilled and the soil compacted over the filter fabric. Silt fences shall be removed upon approval by Entergy.

### 7.2 Straw Bales

Straw bales for check dams shall be placed in a single row with the center or lowest bale placed upstream against and overlapping the two adjacent bales to provide a lower, reinforced spillway. Straw bales for dikes shall be placed in a single row lengthwise on the contour. Ends of adjacent bales shall tightly abut one another. Straw bales shall be installed so that bindings are oriented around the sides rather than along the tops and bottoms of the bales in order to prevent deterioration of the bindings. The barrier shall be entrenched and backfilled. A trench shall be excavated the width of a bale and the length of the proposed barrier to a minimum depth of 4 inches. After the bales are staked and chinked (gaps filled by wedging with straw), the excavated soil shall be backfilled against the barrier. Backfill soil shall conform to the ground level on the downhill side and shall be built up to 4 inches against the uphill side of the barrier. Loose straw shall be scattered over the area immediately uphill from a straw bale barrier to increase barrier efficiency. Each bale shall be securely anchored by at least two stakes driven through the bale. The first stake, steel post, or rebar in each bale shall be driven toward the previously laid bale to force the bales together. Stakes, steel posts, or rebars shall be driven a minimum 18 inches deep into the ground to securely anchor the bales.

## 7.3 Erosion Control Matting

### 7.3.1 The matting shall be applied after the area has been properly shaped, limed,

This document is the property of Entergy Services, Inc. and contains confidential and proprietary information owned by Entergy Services, Inc. Any copying, use, or disclosure of this information without the written permission of Entergy Services, Inc. is strictly prohibited. This material is protected under trade secret and unfair competition laws and the expression of the information contained herein is protected under Federal copyright laws. Violations thereof may result in criminal penalties and fines.

|  |   |                                  |
|--|---|----------------------------------|
| Title: <b>Erosion and Sediment Control Measures Construction Specification</b> | Standard No.:<br><b>ES0101, Rev. 00</b> | Effective Date:<br><b>Dec-04</b> |
|--|---|----------------------------------|

fertilized and seeded as specified in the SWPPP.

**7.3.2** The materials shall be applied according to the manufacturer's recommendations. Size and gauge of staples, staple spacing, overlap of materials, direction of matting, etc., shall follow the manufacturer's instructions for installation for the site conditions. The Contractor shall supply Entergy with manufacturer's guidelines before installation.

**7.3.3** The Contractor shall maintain the matting areas until all work on the entire project has been completed and accepted.

**7.3.4** Additional work and materials required because of loss through erosion will be paid for under the pertinent contract items. Additional work and materials required due to the Contractor's negligence in properly installing or maintaining the completed work shall be accomplished at no extra cost to Entergy.

#### **7.4 Rock Check Dams**

Rock ditch checks shall be constructed as shown in the SWPPP or as directed by Entergy. The overflow area in the center of the check dam shall be constructed lower than the sides.

#### **7.5 Baled Straw Check Dams**

Bales for baled straw check dams shall be installed so that the bindings are oriented around the sides of the bales and not along the tops and bottoms. The bales shall be keyed into the ground a minimum of 4" and securely held in place by stakes, tie wire, and/or other methods that will prevent floating and/or displacement. No gaps shall be left between bales. The number of bales required and the specific arrangement of them will vary with the conditions at each site. Bales that become displaced shall be retrieved and re-installed, if suitable. Bales that become unserviceable in their original locations shall be removed and replaced.

#### **7.6 Sandbag Check Dams**

**7.6.1** Sandbags for sandbag check dams shall be filled approximately 3/4 full, shall weigh a minimum of 55 pounds, and shall be securely closed.

**7.6.2** Sandbags shall be placed in the ditches at locations shown in the SWPPP or as directed by Entergy. They shall be laid in horizontal courses and successive courses shall break joints with preceding ones. The sacks shall be rammed and packed against each other and tamped on the surface to secure a uniform surface. The number of bags required and the arrangement at each installation will vary with on-site conditions.

#### **7.7 Slope Drains**

Slope drains shall be constructed as shown on the plans or as directed by Entergy. Pipe for slope drains shall be installed down the slope as shown in the SWPPP and securely held in place by anchor stakes or other devices as approved by Entergy.

This document is the property of Entergy Services, Inc. and contains confidential and proprietary information owned by Entergy Services, Inc. Any copying, use, or disclosure of this information without the written permission of Entergy Services, Inc. is strictly prohibited. This material is protected under trade secret and unfair competition laws and the expression of the information contained herein is protected under Federal copyright laws. Violations thereof may result in criminal penalties and fines.

Copyright Unpublished Work Entergy Services, Inc.  
All Rights Reserved

|  |                                      |                               |
|--|--------------------------------------|-------------------------------|
| Title: <b>Erosion and Sediment Control Measures Construction Specification</b> | Standard No.: <b>ES0101, Rev. 00</b> | Effective Date: <b>Dec-04</b> |
|--|--------------------------------------|-------------------------------|

**7.8 Diversion Ditches**

Excavation and grading for diversion ditches shall be according to the dimensions and at the locations shown in the SWPPP or as directed by Entergy.

**7.9 Sediment Basins**

Sediment basins shall be constructed to the dimensions shown in the SWPPP or as directed by Entergy. The soil used in basin construction shall be amended, compacted, and stabilized. Dumped riprap and geotextile for a sediment basin outlet shall be placed on the spillway as shown on the plans.

**7.10 Dumped Riprap**

**7.10.1** Prior to placing filter blanket and riprap, the slopes shall be shaped as shown on the plans.

**7.10.2** Geotextile fabric used for filter fabric shall be placed directly on the prepared surface. Fabric sections may be placed vertically or horizontally on the slope. Adjacent fabric sections shall be joined by overlapping a minimum of 2' at the edges and pinning the overlapped strip with U-shaped wire pins, single shaped steel pins with metal disc heads, or similar fasteners. The fasteners shall be 6" or more in length and shall hold the fabric firmly in place. Fasteners shall be inserted through both strips of overlapped fabric at intervals of approximately 4' along the overlap. Additional pins shall be installed as necessary to prevent displacement of the fabric. Fabric shall be overlapped in the direction of water flow. The fabric shall be turned down and buried approximately 12" deep at the exterior limits. No construction equipment will be permitted directly on the fabric.

**7.10.3** Stone or broken concrete for dumped riprap shall be placed in such a manner as to produce a reasonably well graded mass of rock with the minimum practicable percentage of voids and shall be constructed to the lines and grades shown on the plans or as directed by the Engineer. Material shall be placed in such a manner as to avoid displacing the underlying material. The larger pieces shall be well distributed throughout the entire mass and the finished riprap shall be free from objectionable pockets of small or large pieces. Hand placing, to a limited extent, may be required, but only to the extent necessary to secure the results specified above. Placing riprap by dumping into chutes or by similar methods likely to cause segregation will not be permitted. Riprap stone shall not be deposited in a manner that will cause damage to the filter blanket. Any damage to fabric during placement of riprap shall be corrected by the Contractor at no cost to Entergy prior to proceeding with the work. Damaged fabric shall be repaired by placing a piece of fabric large enough to cover the damaged area and overlapping and pinning in accordance with this section.

**7.11 Sediment Removal and Disposal**

Sediment collected in the various erosion and sediment control devices shall be removed when needed and as directed by Entergy. Sediment basins and ditch checks shall have sediment removed when their capacity is reduced by half. Silt fences shall have sediment removed when a deposit covers 1/3 the height of the structure. Sediment removed shall be

This document is the property of Entergy Services, Inc. and contains confidential and proprietary information owned by Entergy Services, Inc. Any copying, use, or disclosure of this information without the written permission of Entergy Services, Inc. is strictly prohibited. This material is protected under trade secret and unfair competition laws and the expression of the information contained herein is protected under Federal copyright laws. Violations thereof may result in criminal penalties and fines.

|  |   |                                  |
|--|---|----------------------------------|
| Title: <b>Erosion and Sediment Control Measures Construction Specification</b> | Standard No.:<br><b>ES0101, Rev. 00</b> | Effective Date:<br><b>Dec-04</b> |
|--|---|----------------------------------|

deposited and stabilized according to the requirements of Entergy. Sediment will normally be incorporated back into the embankment construction or as directed by Entergy.

## **8.0 Inspections**

### **8.1 General**

The Contractor shall inspect disturbed areas of the construction site, areas used for storage of materials that are exposed to precipitation that have not been finally stabilized, stabilization practices, structural practices, other controls and areas where vehicles exit the site at least once every seven (7) calendar days and within 24 hours of the end of any storm that produces 0.5 inches or more rainfall at the site. Where sites have been finally stabilized, such inspection shall be conducted at least once every month.

### **8.2 Inspections Details**

Disturbed areas and areas used for material storage that are exposed to precipitation shall be inspected for evidence of, or the potential for, pollutants entering the drainage system. Erosion and sediment control measures identified in the Storm Water Pollution Prevention Plan shall be observed to ensure that they are operating correctly. Discharge locations or points shall be inspected to ascertain whether erosion control measures are effective in preventing significant impacts to receiving waters. Locations where vehicles exit the site shall be inspected for evidence of offsite sediment tracking.

### **8.3 Inspection Reports**

For each inspection conducted, the Contractor shall prepare a report summarizing the scope of the inspection, name(s) and qualifications of personnel making the inspection, the date(s) of the inspection, major observations relating to the implementation of the Storm Water Pollution Prevention Plan, maintenance performed, and actions taken. The report shall be furnished to Entergy within 24 hours of the inspection. A copy of the inspection report shall be maintained on the job site.

## **9.0 Not Used**

## **10.0 Not Used**

## **11.0 Responsibilities**

### **11.1 Interpretation**

Interpretation of this standard is the responsibility of the author and/or reviewers

### **11.2 Deviation**

The Manager of Transmission Design and the Manager of Transmission Construction are responsible for assuring that transmission line facilities are installed in accordance with this standard. Deviations from this standard may be made with the consent of the Manager of Transmission Design and the Manager of Transmission Construction or an approved agent thereof. Any deviations granted shall be reported to the Manager of Transmission Design and

This document is the property of Entergy Services, Inc. and contains confidential and proprietary information owned by Entergy Services, Inc. Any copying, use, or disclosure of this information without the written permission of Entergy Services, Inc. is strictly prohibited. This material is protected under trade secret and unfair competition laws and the expression of the information contained herein is protected under Federal copyright laws. Violations thereof may result in criminal penalties and fines.

|  |   |                                  |
|--|---|----------------------------------|
| Title: <b>Erosion and Sediment Control Measures<br/>Construction Specification</b> | Standard No.:<br><b>ES0101, Rev. 00</b> | Effective Date:<br><b>Dec-04</b> |
|--|---|----------------------------------|

the Manager of Design Services for consideration for inclusion in the standard. No other employee is granted independent authority to grant deviations.

## **12.0 Acknowledgments**

Robert Durham was helpful in providing specifications and drawings from previous projects.

## **13.0 Attachments**

- 1) Straw Bale Check Dam.
- 2) Slope Installation.
- 3) Dissipator.
- 4) Riprap Slope Protection.
- 5) Rock Check Dam.
- 6) Straw Bale Dike.
- 7) Silt Fence.
- 8) Temporary Diversion Dike.
- 9) Typical Stream Crossing.
- 10) Typical Cross Slope Protection.
- 11) Typical Down Slope Protection.
- 12) Typical Wet Weather Conveyance.
- 13) Rolling Dip and Waterbar.
- 14) Inspection Report, Erosion and Sediment Control Measures.

# Attachment 1 Straw Bale Check Dam

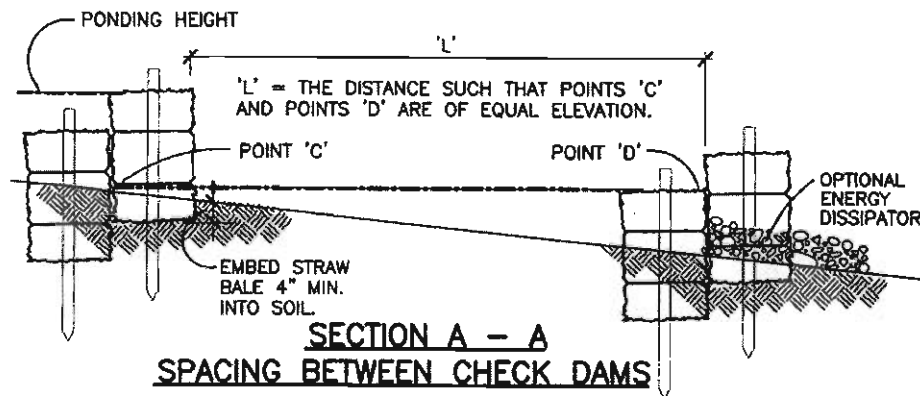
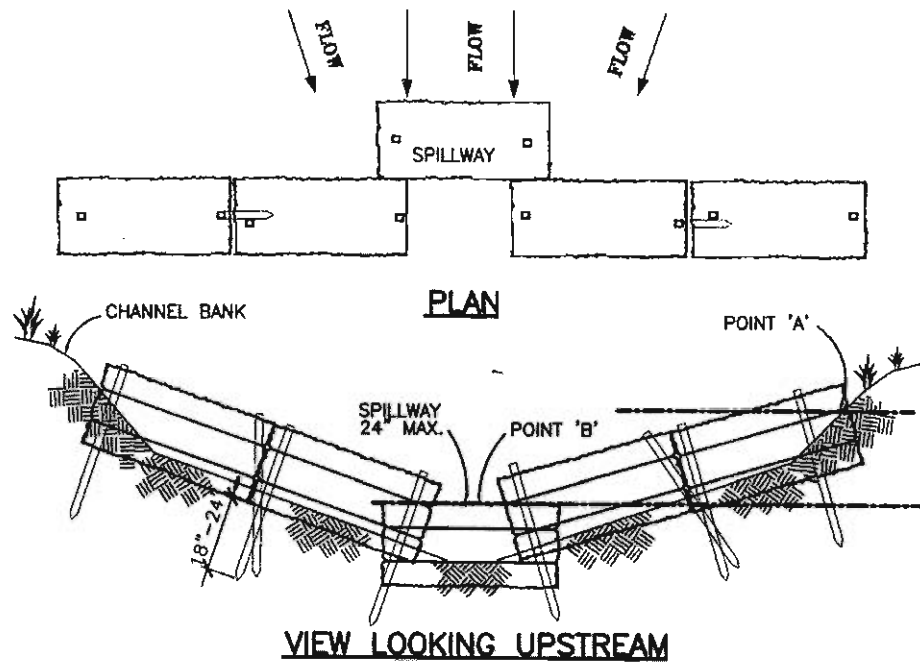

**NOTES:**

1. EMBED BALES 4" INTO THE SOIL AND "KEY" BALES INTO THE CHANNEL BANKS.
2. POINT 'A' MUST BE HIGHER THAN POINT 'B'. (SPILLWAY HEIGHT)
3. PLACE BALES PERPENDICULAR TO THE FLOW WITH ENDS TIGHTLY ABUTTING. USE STRAW, ROCKS OR FILTER FABRIC TO FILL ANY GAPS AND TAMP BACKFILL MATERIAL TO PREVENT EROSION OR FLOW AROUND THE BALES.
4. SPILLWAY HEIGHT SHALL NOT EXCEED 24".
5. INSPECT AFTER EACH SIGNIFICANT STORM, MAINTAIN AND REPAIR PROMPTLY.

|  |             |            |  |
|--|-------------|------------|--|
| ENERGY SERVICES, INC.                                    |             |            |  |
| STRAW BALE CHECK DAM<br>STORM WATER POLLUTION PREVENTION |             |            |  |
| STD NO. ES0101   | SCALE: NONE |            |  |
| No. TNSW001A0  |             |            |  |
| PLOT 1=1   |             | SH. 1 OF 1 |  |

|     |          |                         |     |     |      |
|-----|----------|-------------------------|-----|-----|------|
| 0   | 10-11-04 | CREATED PER FIELD NOTES | TWF | SK  |      |
| NO. | DATE     | REVISION                | BY  | CHK | APPR |
|     | tfn90    | 10/19/2004              |     |     |      |

C:\temp\AM-Work\ifinc90\M-Cctapetsp047.D-TDoc\S-Template\ESI\STANDARD\STransmission\TNSW001A0.DWG, 01/05/2005 07:15:54 AM, tfnc90, drogill

## Attachment 2 Slope Installation

MATS/BLANKETS SHOULD BE INSTALLED VERTICALLY DOWNSLOPE.

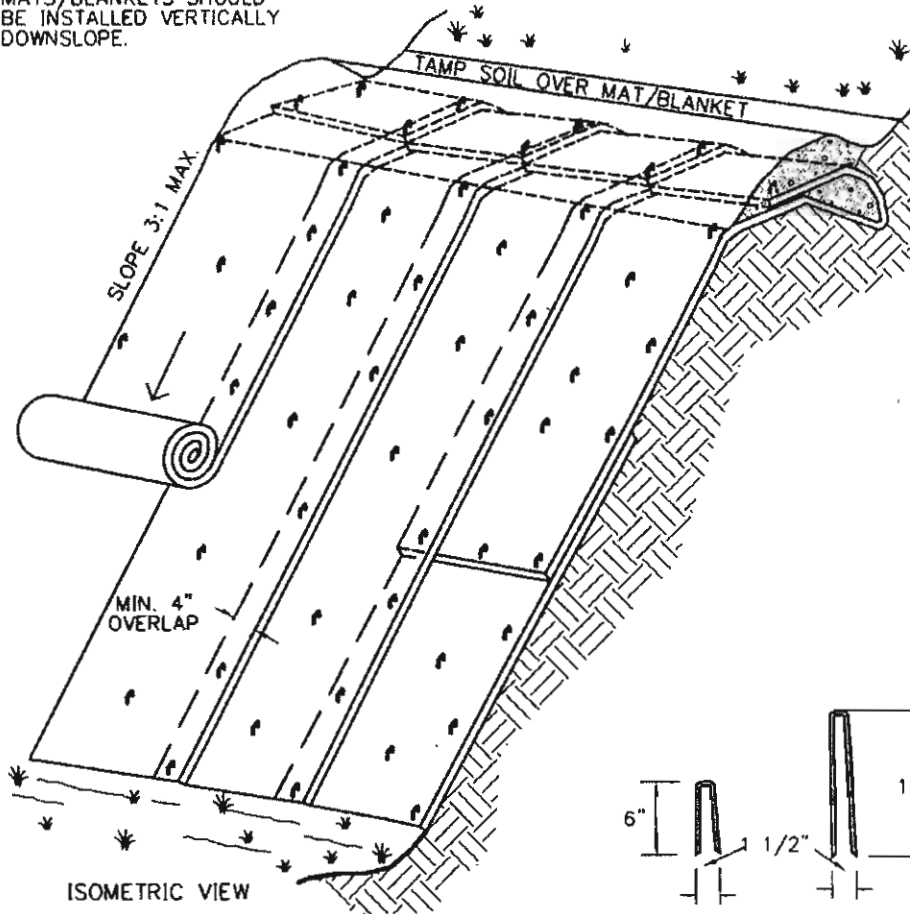

ISOMETRIC VIEW

### TYPICAL SLOPE SOIL STABILIZATION

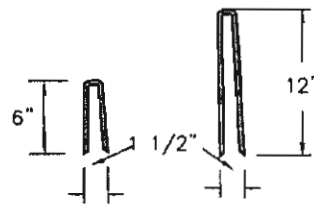

**STAPLES**

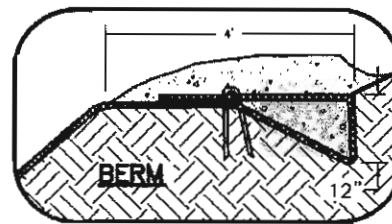

NOT TO SCALE

**NOTES:**

1. SLOPE SURFACE SHALL BE FREE OF ROCKS, CLODS, STICKS AND GRASS. MATS/BLANKETS SHALL HAVE GOOD SOIL CONTACT.
2. APPLY PERMANENT SEEDING BEFORE PLACING BLANKETS.
3. LAY BLANKETS LOOSELY AND STAKE OR STAPLE TO MAINTAIN DIRECT CONTACT WITH THE SOIL. DO NOT STRETCH. STAPLE SPACING PER MANUFACTURER'S RECOMMENDATIONS.

|  |             |
|--|-------------|
| ENERGY SERVICES, INC.                                  |             |
| SLOPE INSTALLATION<br>STORM WATER POLLUTION PREVENTION |             |
| STD NO. ES0101   | SCALE: NONE |
| No. TNSW002A0  |             |
| PLOT 1=1 SH. 1 OF 1                                    |             |

|     |          |                         |     |      |       |
|-----|----------|-------------------------|-----|------|-------|
| 0   | 10-11-04 | CREATED PER FIELD NOTES | TWF | SK   |       |
| NO. | DATE:    | REVISION                | BY: | CHK: | APPR: |
|     | tffc90   | 10/19/2004              |     |      |       |

C:\temp\AM-Work\ffinc90\W-Cctapetsp047.D-TDcCS.S-Template\ESINSTANDARDS\Transmissions\TNSW002A0.DWG, 01/05/2005 07:20:18 AM, tffc90, drogill

# Attachment 3 Dissipator

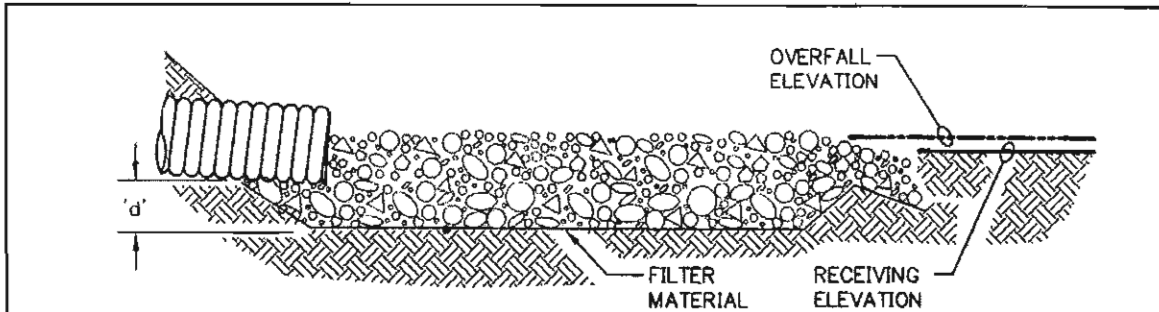

## SECTION

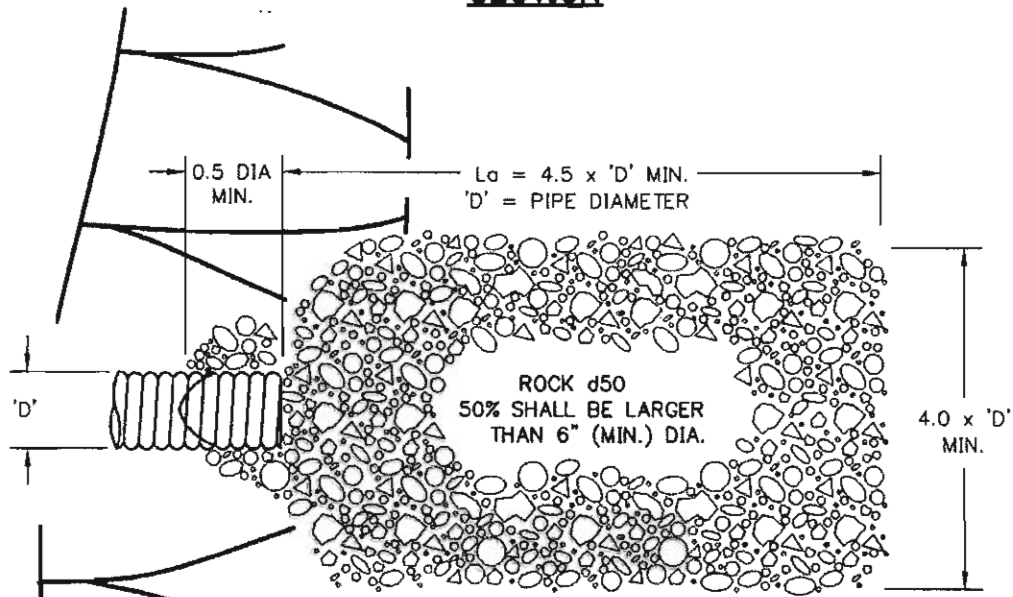

## PLAN

**NOTES:**

1. 'La' = LENGTH OF APRON. DISTANCE 'La' SHALL BE OF SUFFICIENT LENGTH TO DISSIPATE ENERGY.
2. APRON SHALL BE SET AT A ZERO GRADE AND ALIGNED STRAIGHT.
3. FILTER MATERIAL SHALL BE FILTER FABRIC OR 6" THICK (MIN.) GRADED GRAVEL LAYER.

|  |        |                      |      |
|--|--------|----------------------|------|
| ENERGY SERVICES, INC.                          |        |                      |      |
| DISSIPATOR<br>STORM WATER POLLUTION PREVENTION |        |                      |      |
| STD NO.  | ES0101 | SCALE:               | NONE |
|  |        | No. <b>TNSW003A0</b> |      |
| PLOT 1=1                                       |        | SH. 1 OF 1           |      |

|     |          |                         |     |     |      |
|-----|----------|-------------------------|-----|-----|------|
| 0   | 10-11-04 | CREATED PER FIELD NOTES | TWF | SK  |      |
| NO. | DATE     | REVISION                | BY  | CHK | APPR |
|     | tfnrc90  | 10/19/2004              |     |     |      |

C:\temp\AM-Work\Tfnrc90M-Cctapetsp047\_D-TDoCS-S-Template\ES\STANDARDS\Transmission\TNSW003A0.DWG, 01/05/2005 07:20:48 AM, tfnrc90, crogill

## Attachment 4 Riprap Slope Protection

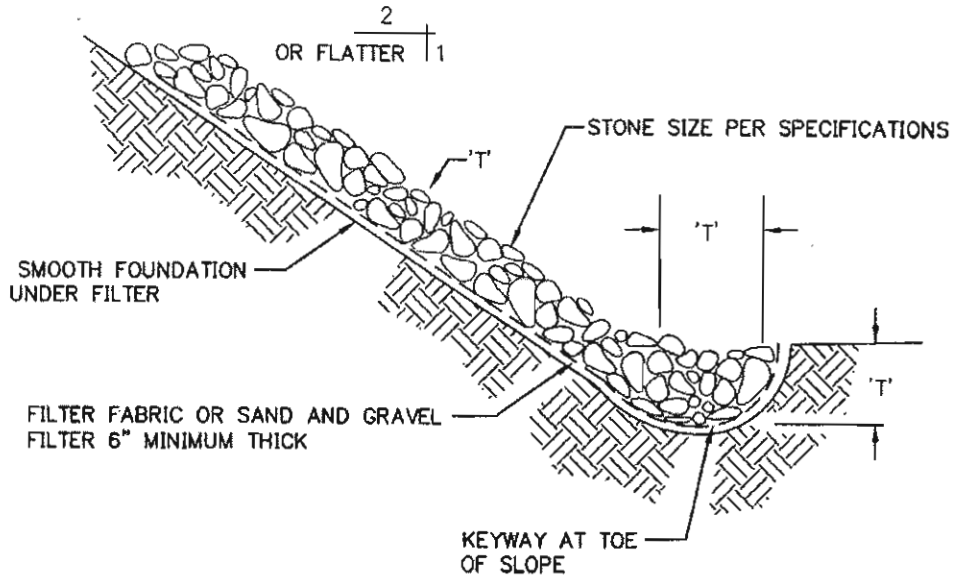

**TYPICAL SECTION**

**NOTE:**

'T' = THICKNESS: THICKNESS SHALL BE AS SHOWN IN SWPPP OR AS DETERMINED BY THE ENGINEER.  
 MINIMUM THICKNESS SHALL BE 1.5x THE MAXIMUM STONE DIAMETER, AND SHALL BE NEVER LESS THAN 12".

|     |          |                         |     |      |      |
|-----|----------|-------------------------|-----|------|------|
| 0   | 10-11-04 | CREATED PER FIELD NOTES | TWF | SK   |      |
| NO. | DATE:    | REVISION                | BY: | CHK: | APPR |
|     | tflnc90  | 10/19/2004              |     |      |      |

|   |        |        |      |
|---|--------|--------|------|
| ENTERGY SERVICES, INC.                                      |        |        |      |
| RIPRAP SLOPE PROTECTION<br>STORM WATER POLLUTION PREVENTION |        |        |      |
| STD NO.   | ES0101 | SCALE: | NONE |
| No. <b>TNSW004A0</b>  |        |        |      |
| PLOT  | 1=1    | SH. 1  | OF 1 |

C:\temp\IAM-Work\flnc90\W-Cctapets\p047.D\DoCS\_S-Template\ESI\STANDARDS\Transmission\TNSW004A0.DWG, 01/05/2005 07:21:21 AM, tflnc90, drogill

# Attachment 5 Rock Check Dam

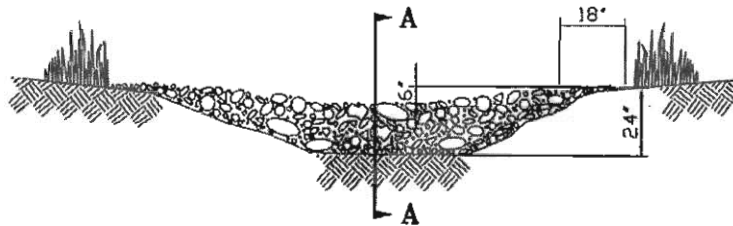

**VIEW LOOKING UPSTREAM**

**NOTE:**

KEY STONE INTO THE DITCH BANKS AND EXTEND IT BEYOND THE ABUTMENTS A MINIMUM OF 18" TO PREVENT OVERFLOW AROUND DAM.

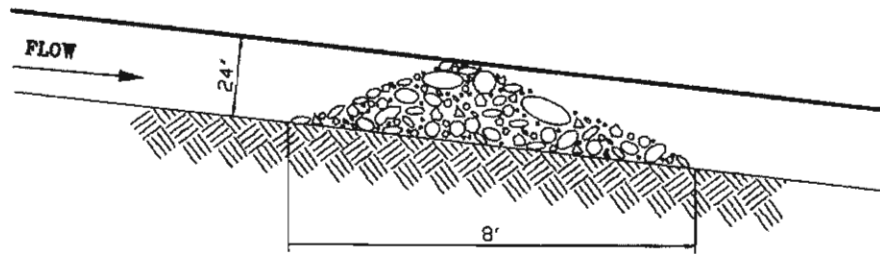

**SECTION A - A**

'L' = THE DISTANCE SUCH THAT POINTS 'A' AND 'B' ARE OF EQUAL ELEVATION.

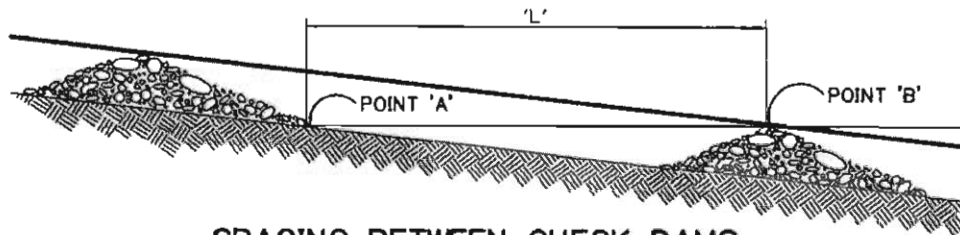

**SPACING BETWEEN CHECK DAMS**

**NOTE:**

1. IF CHANNEL DEPTH IS LESS THAN 24", ADJUST DAM HEIGHT AND SPACING AS REQUIRED.

|  |        |               |            |
|--|--------|---------------|------------|
| ENTERGY SERVICES, INC.                             |        |               |            |
| ROCK CHECK DAM<br>STORM WATER POLLUTION PREVENTION |        |               |            |
| STD NO.  | ES0101 | SCALE:        | NONE       |
|  |        | No. TNSW005A0 |            |
|  |        | PLOT 1=1      | SH. 1 OF 1 |

|     |          |                         |     |     |      |
|-----|----------|-------------------------|-----|-----|------|
| 0   | 10-11-04 | CREATED PER FIELD NOTES | TWF | SK  |      |
| NO. | DATE     | REVISION                | BY  | CHK | APPR |
|     | tfnrc90  | 10/19/2004              |     |     |      |

C:\temp\AM-Work\tfnrc90\W-Cctapetisp047.D-TDcCS.S-Template\ES\STANDARDS\Transmission\TNSW005A0.DWG, 01/05/2005 07:21:57 AM, tfnc90, drogill

# Attachment 6 Straw Bale Dike

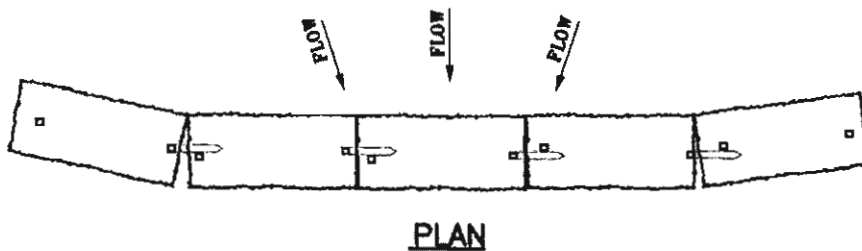
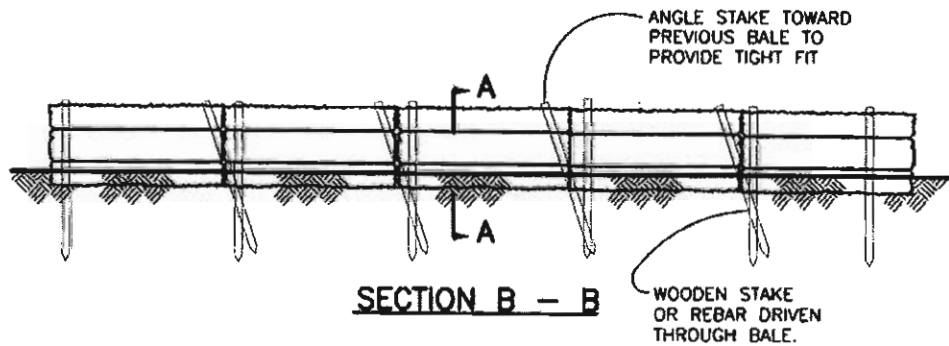
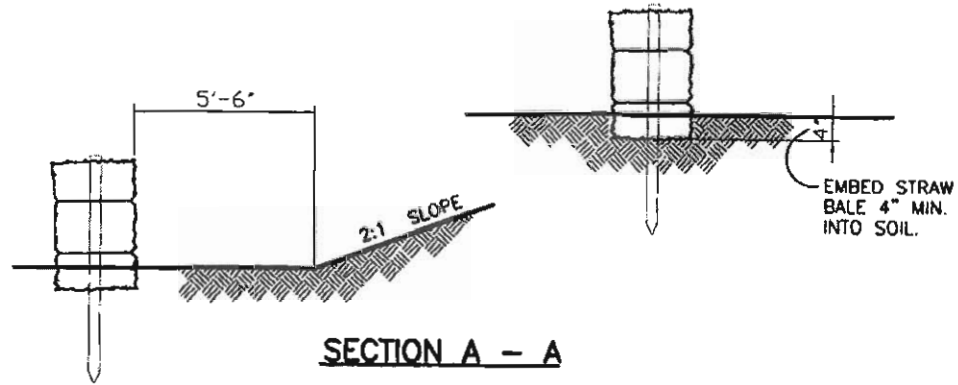

**NOTES:**

1. THE STRAW BALES SHALL BE PLACED ON SLOPE CONTOUR.
2. BALES TO BE PLACED IN A ROW WITH THE ENDS TIGHTLY ABUTTING. USE STRAW, ROCKS, OR FILTER FABRIC TO FILL GAPS BETWEEN THE BALES AND TAMP THE BACKFILL MATERIAL TO PREVENT EROSION OR FLOW AROUND BALES.

|   |             |
|---|-------------|
| ENTERGY SERVICES, INC.                              |             |
| STRAW BALE DIKE<br>STORM WATER POLLUTION PREVENTION |             |
| STD NO. ES0101                                      | SCALE: NONE |
| No. TNSW006A0                                       |             |
|   |             |
| PLOT 1=1  | SH. 1 OF 1  |

|     |          |                         |     |      |      |
|-----|----------|-------------------------|-----|------|------|
| 0   | 10-11-04 | CREATED PER FIELD NOTES | TMF | SK   |      |
| NO. | DATE:    | REVISION                | BY: | CHK: | APPR |
|     | tinc90   | 10/19/2004              |     |      |      |

C:\temp\AM-Work\inc90\M-Cctapets047.D-TDoCS,S-Template\ES\STANDARDS\Transmission\TNSW006A0.DWG, 01/05/2005 07:22:25 AM, tinc90, drogill

# Attachment 7 Silt Fence

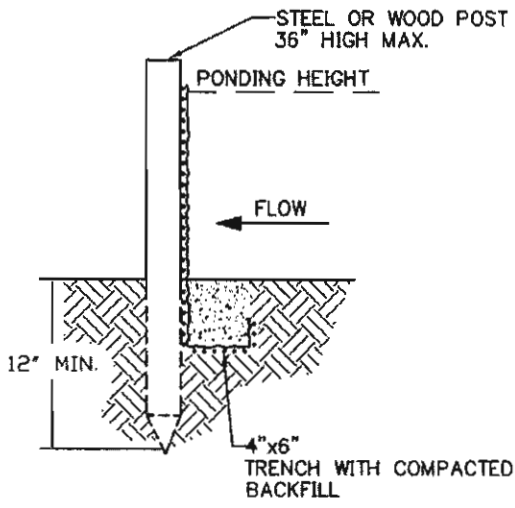
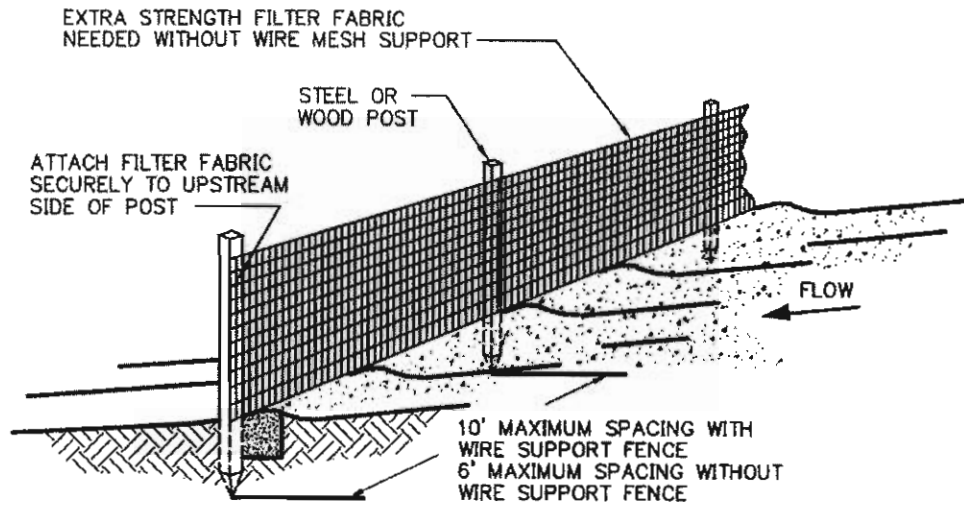

**TRENCH DETAIL**

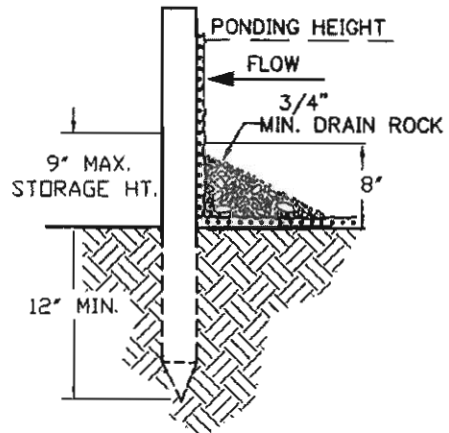

**INSTALLATION WITHOUT TRENCHING**

**NOTES:**

1. SILT FENCE SHALL BE PLACED ON SLOPE CONTOURS TO MAXIMIZE PONDING EFFICIENCY.
2. INSPECT AND REPAIR FENCE AFTER EACH STORM EVENT AND REMOVE SEDIMENT WHEN NECESSARY. 9" MAXIMUM RECOMMENDED STORAGE HEIGHT.
3. REMOVED SEDIMENT SHALL BE DEPOSITED TO AN AREA THAT WILL NOT CONTRIBUTE SEDIMENT OFF-SITE AND CAN BE PERMANENTLY STABILIZED.

|  |        |                      |            |
|--|--------|----------------------|------------|
| ENTERGY SERVICES, INC.                         |        |                      |            |
| SILT FENCE<br>STORM WATER POLLUTION PREVENTION |        |                      |            |
| STD NO.  | ES0101 | SCALE:               | NONE       |
|  |        | No. <b>TNSW007A0</b> |            |
|  |        | PLOT 1=1             | SH. 1 OF 1 |

|     |          |                         |     |     |      |
|-----|----------|-------------------------|-----|-----|------|
| 0   | 10-11-04 | CREATED PER FIELD NOTES | TYF | SK  |      |
| NO. | DATE     | REVISION                | BY  | CHK | APPR |
|     | tffnc90  | 10/19/2004              |     |     |      |

C:\temp\AM-Work\ffnc90\W-Cctapetsp047.D-TDocS\_S-Template\ESI\STANDARDS\Transmission\TNSW007A0.DWG, 01/05/2005 07:22:58 AM, tffnc90, drogill

# Attachment 8 Temporary Diversion Dike

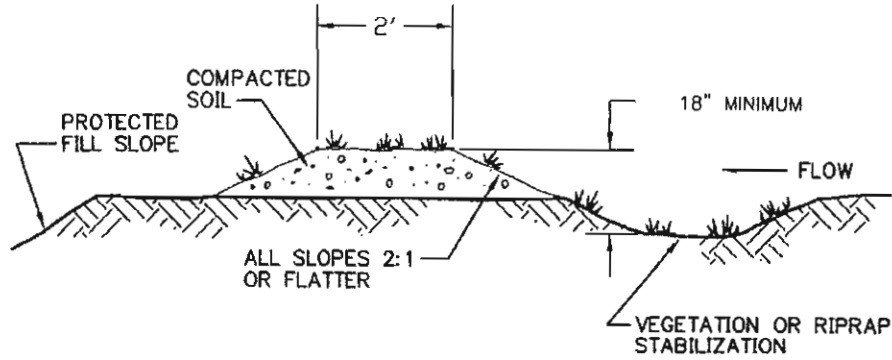

**TYPICAL FILL DIVERSION**

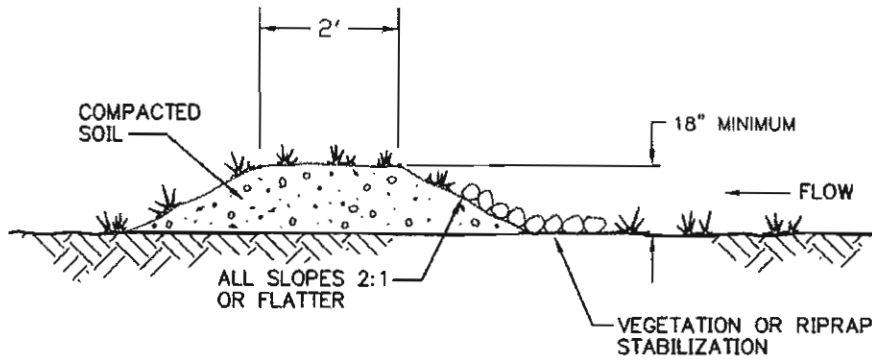

**TYPICAL TEMPORARY DIVERSION DIKE**

**NOTES:**

1. THE CHANNEL BEHIND THE DIKE SHALL HAVE POSITIVE GRADE TO A STABILIZED OUTLET.
2. THE DIKE SHALL BE ADEQUATELY COMPACTED TO PREVENT FAILURE.
3. THE DIKE SHALL BE STABILIZED WITH TEMPORARY OR PERMANENT SEEDING OR RIPRAP.

|  |             |
|--|-------------|
| ENTERGY SERVICES, INC.                                       |             |
| TEMPORARY DIVERSION DIKE<br>STORM WATER POLLUTION PREVENTION |             |
| STD NO. ES0101   | SCALE: NONE |
| No. <b>TNSW008A0</b>   |             |
| PLOT 1=1   | SH. 1 OF 1  |

|    |          |                         |     |     |      |
|----|----------|-------------------------|-----|-----|------|
| D  | 10-11-04 | CREATED PER FIELD NOTES | TWF | SK  |      |
| ND | DATE     | REVISION                | BY  | CHK | APPR |
|    | tfinc90  | 10/19/2004              |     |     |      |

C:\temp\AM-Work\finc90\W-Cctapetsp047.D-TDcCS.S-Template\ESTANDARDSD\Transmission\TNSW008A0.DWG, 01/05/2005 07:23:37 AM, tfinc90, drogill

# Attachment 9 Typical Stream Crossing

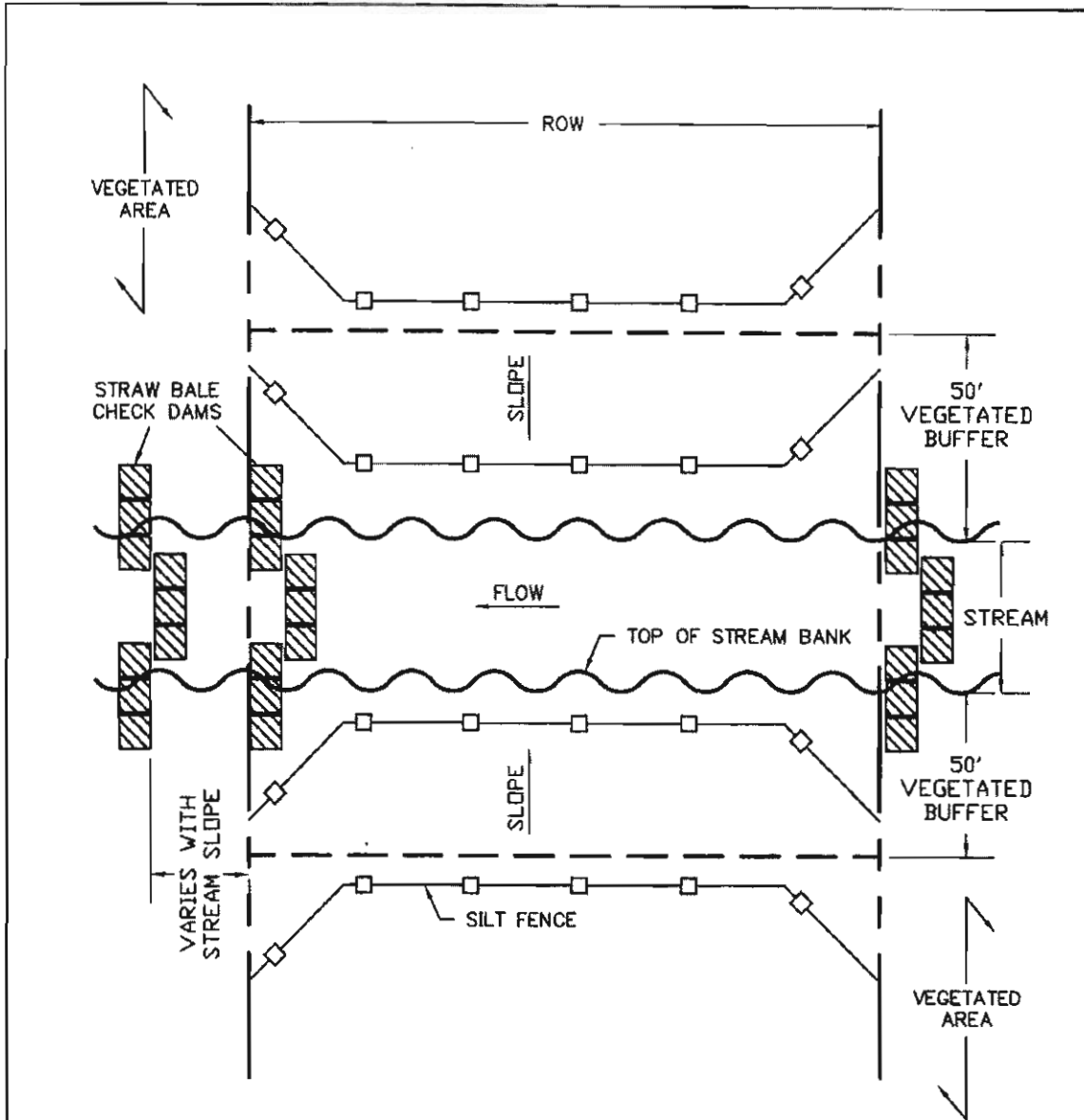

**NOTES:**

1. NO FILL ALLOWED IN STREAM.
2. INSTALL CONTROLS PER DETAILS.

|   |             |
|---|-------------|
| ENTERGY SERVICES, INC.                                      |             |
| TYPICAL STREAM CROSSING<br>STORM WATER POLLUTION PREVENTION |             |
| STD NO. ES0101  | SCALE: NONE |
| <b>No. TNSW009A0</b>  |             |
| PLOT 1=1  | SH. 1 OF 1  |

|     |          |                         |     |      |      |
|-----|----------|-------------------------|-----|------|------|
| 0   | 10-11-04 | CREATED PER FIELD NOTES | TWF | SK   |      |
| NO. | DATE     | REVISION                | BY: | CHK: | APPR |
|     | tfinc90  | 10/19/2004              |     |      |      |

C:\temp\AM-Work\tfinc90\W-Cclapetp047.D-TDocS\S-Template\ESI\STANDARD\STransmission\TNSW009A0.DWG, 01/05/2005 07:24:06 AM, tfinc90, drogill

# Attachment 10 Typical Cross Slope Protection

C:\temp\AM-Work\trinc90M-Cctapetsp047.D-TD\CS-S-Template\EST\STANDARD\RDSTransmission\TNSW010A0.DWG, 01/05/2005 07:24:37 AM, trinc90, drogill

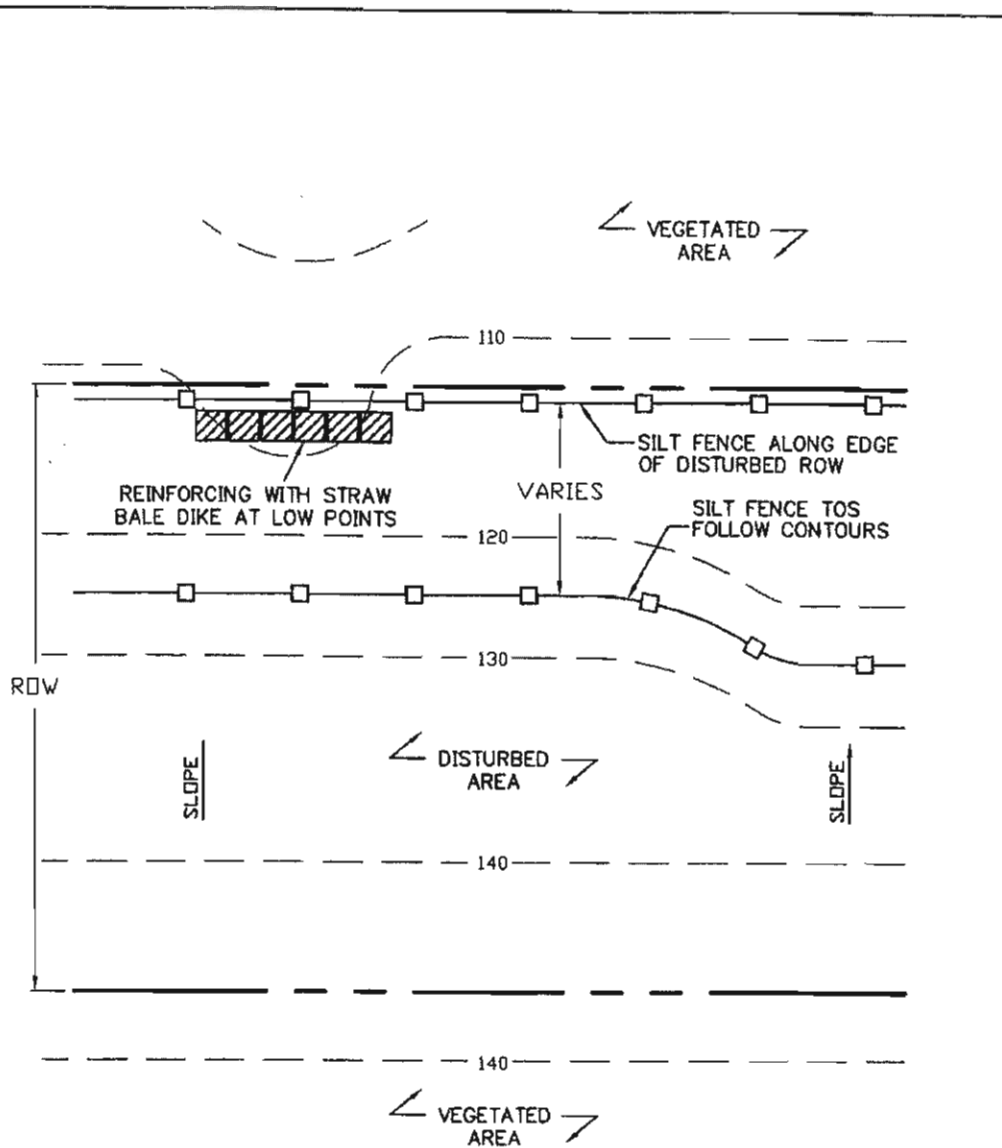

**NOTES:**

1. INSTALL SILT FENCE TO FOLLOW CONTOURS. SPACING VARIES PER SLOPE GRADE.
2. REINFORCE SILT FENCE WITH HAY BALES AT ANY LOW POINTS. SEE STRAW BALE DIKE INSTALLATION DETAILS.

|  |             |
|--|-------------|
| ENTERGY SERVICES, INC.   |             |
| TYPICAL CROSS SLOPE PROTECTION<br>STORM WATER POLLUTION PREVENTION |             |
| STD NO. ES0101   | SCALE: NONE |
| <b>No. TNSW010A0</b>   |             |
|  |             |
| PLOT 1=1   | SH. 1 OF 1  |

|     |          |                         |     |      |       |
|-----|----------|-------------------------|-----|------|-------|
| 0   | 10-11-04 | CREATED PER FIELD NOTES | TWF | SK   |       |
| NO. | DATE:    | REVISION                | BY: | CHK: | APPR: |
|     | trinc90  | 10/19/2004              |     |      |       |

# Attachment 11 Typical Down-Slope Protection

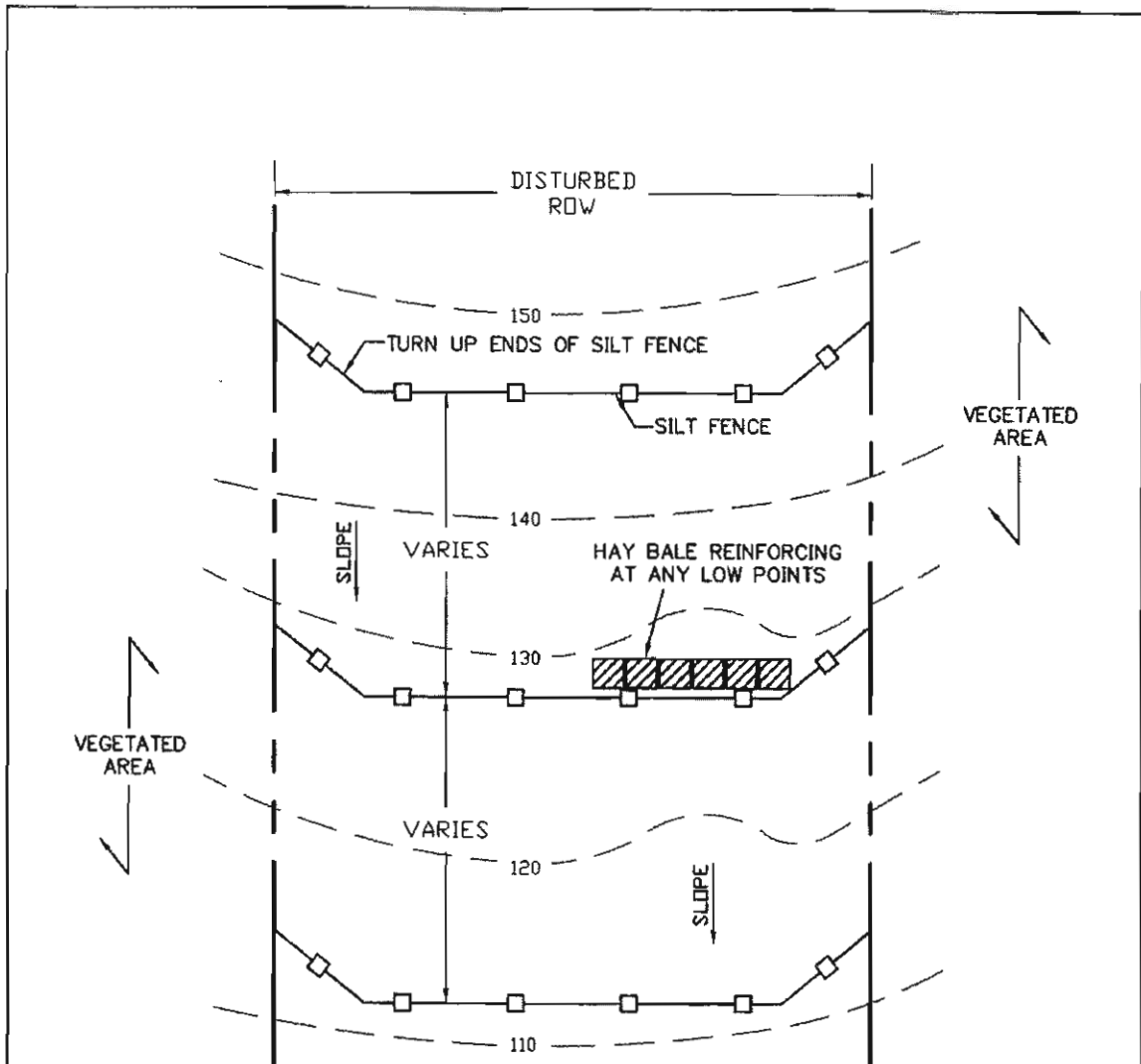

**NOTES:**

1. INSTALL SILT FENCE TO FOLLOW CONTOURS. SPACING VARIES PER SLOPE GRADE.
2. REINFORCE SILT FENCE WITH HAY BALES AT ANY LOW POINTS. SEE STRAW BALE DIKE INSTALLATION DETAILS.

|   |             |                     |  |
|---|-------------|---------------------|--|
| ENERGY SERVICES, INC.   |             |                     |  |
| TYPICAL DOWN SLOPE PROTECTION<br>STORM WATER POLLUTION PREVENTION |             |                     |  |
| STD NO. ES0101  | SCALE: NONE |                     |  |
| No. TNSW011A0   |             | PLOT 1=1 SH. 1 OF 1 |  |
|   |             |                     |  |

|     |          |                         |     |     |      |
|-----|----------|-------------------------|-----|-----|------|
| 0   | 10-11-04 | CREATED PER FIELD NOTES | TWF | SK  |      |
| NO. | DATE     | REVISION                | BY  | CHK | APPR |
|     | tfnrc90  | 10/20/2004              |     |     |      |

C:\temp\AM-Work\Tfnrc90\W-Cctapetp047.D-TDcCS.S-Template\ESTANDARD\SDSITransmission\TNSW011A0.DWG, 01/05/2005 07:25:06 AM, tfnc90, drogill

# Attachment 12 Typical Wet Weather Conveyance

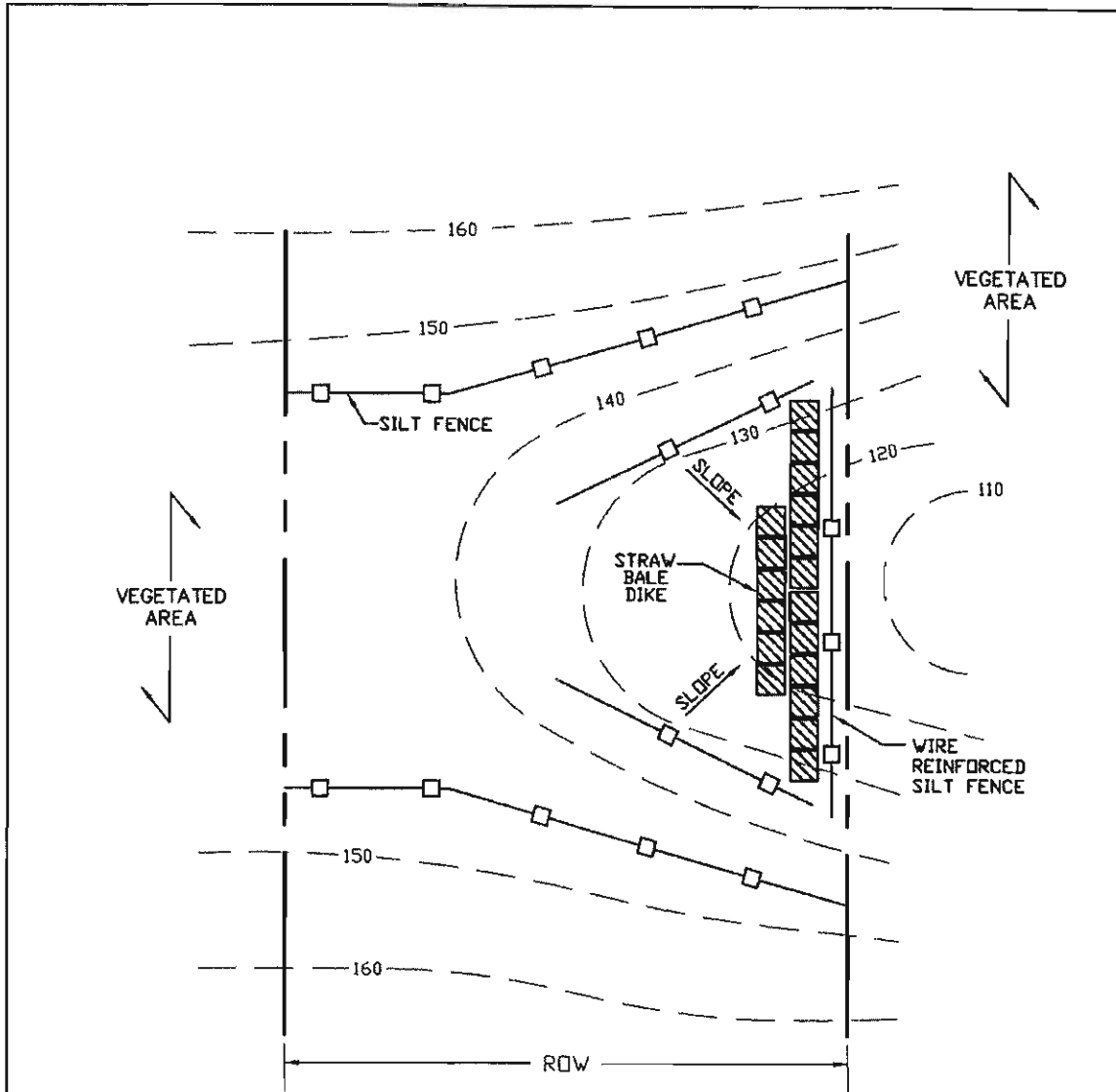

**NOTES:**

1. INSTALL SILT FENCE TO FOLLOW CONTOURS. SPACING VARIES PER SLOPE GRADE.
2. REINFORCE SILT FENCE WITH HAY BALES AT ANY LOW POINTS. SEE STRAW BALE DIKE INSTALLATION DETAILS.

|  |        |                      |            |
|--|--------|----------------------|------------|
| ENTERGY SERVICES, INC.   |        |                      |            |
| TYPICAL WET WEATHER CONVEYANCE<br>STORM WATER POLLUTION PREVENTION |        |                      |            |
| STD NO.  | ES0101 | SCALE:               | NONE       |
|  |        | <b>No. TNSW012A0</b> |            |
|  |        | PLOT 1=1             | SH. 1 OF 1 |

| NO. | DATE:    | REVISION                | TWF | SK | CHK: | APPR |
|-----|----------|-------------------------|-----|----|------|------|
| 0   | 10-11-04 | CREATED PER FIELD NOTES |     |    |      |      |
|     |          | REVISION                |     |    |      |      |
|     |          |                         |     |    |      |      |

tfinc90                      10/19/2004

C:\temp\AM-Work\tfinc90\W-Contapetsp047.D-TDcS,S-Template\ES\STANDARDS\Transmission\TNSW012A0.DWG, 01/05/2005 07:25:34 AM, tfinc90, drogill

# Attachment 13 Rolling Dip and Waterbar

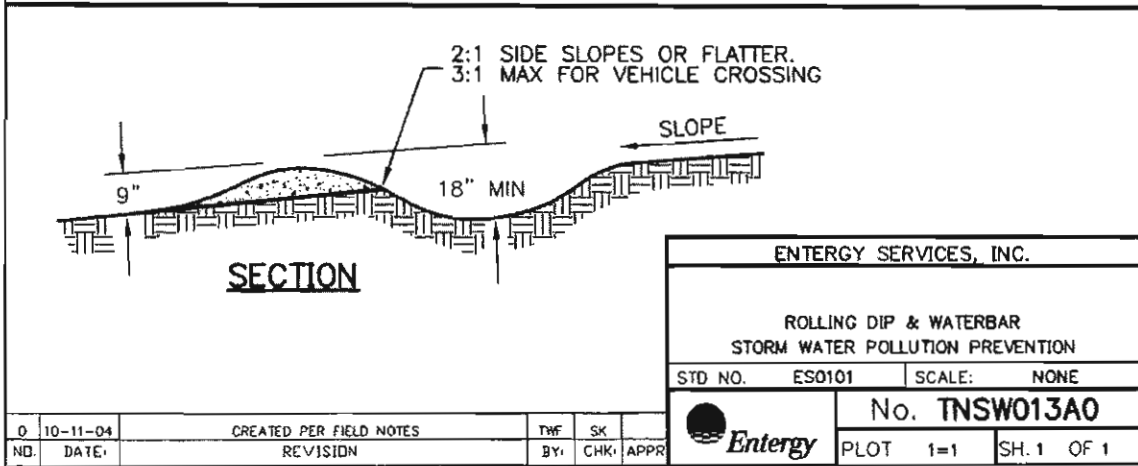
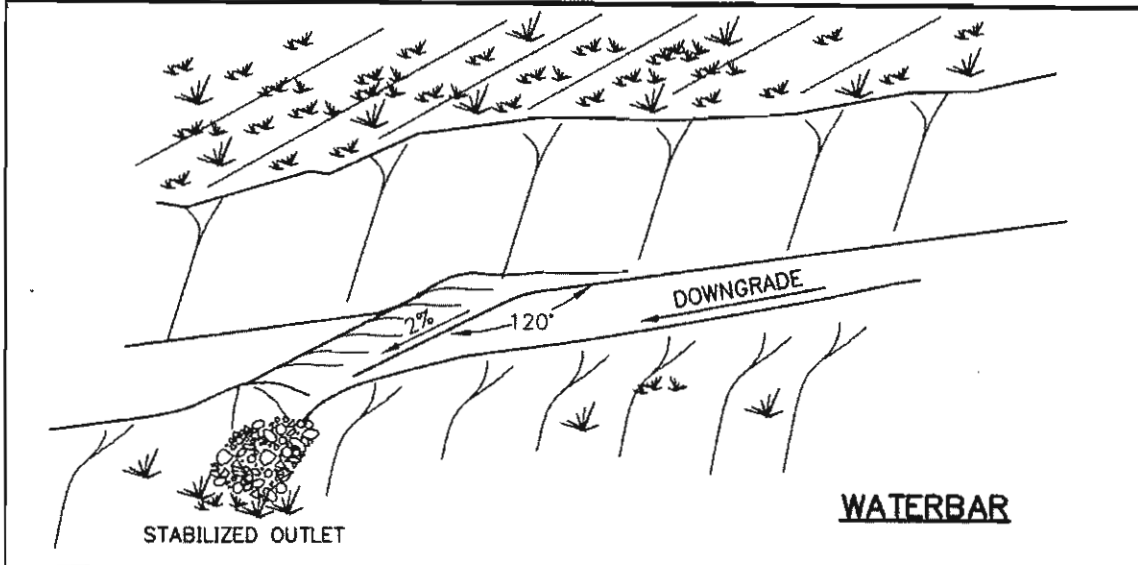
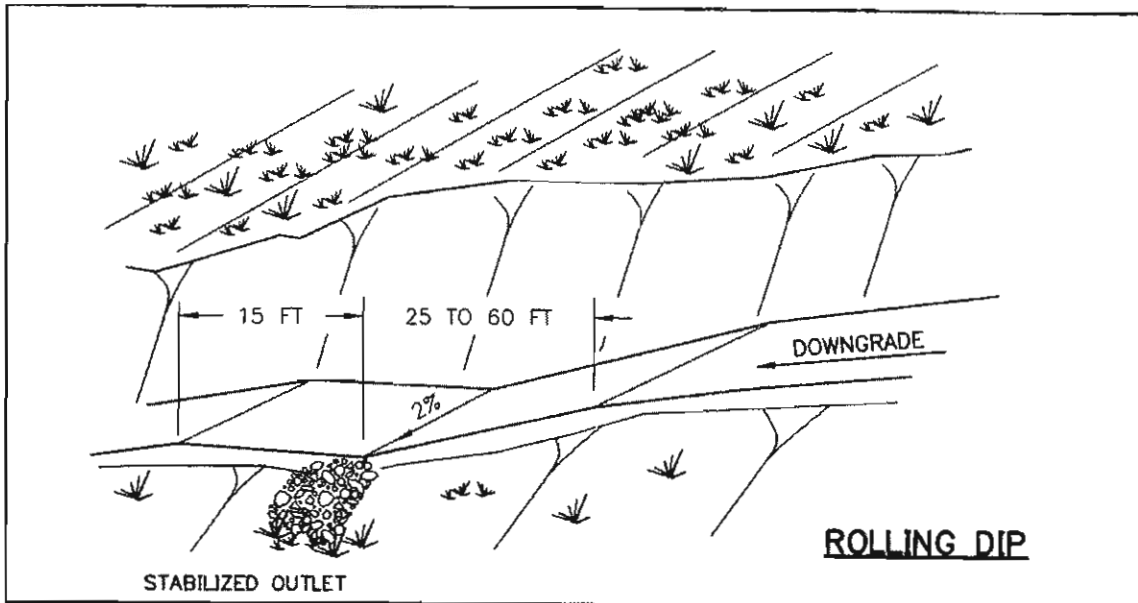

|  |        |               |            |
|--|--------|---------------|------------|
| ENTERGY SERVICES, INC.                                     |        |               |            |
| ROLLING DIP & WATERBAR<br>STORM WATER POLLUTION PREVENTION |        |               |            |
| STD NO.  | ES0101 | SCALE:        | NONE       |
|  |        | No. TNSW013A0 |            |
|  |        | PLOT 1=1      | SH. 1 OF 1 |

|     |          |                         |     |      |       |
|-----|----------|-------------------------|-----|------|-------|
| 0   | 10-11-04 | CREATED PER FIELD NOTES | THF | SK   |       |
| ND. | DATE.    | REVISION                | BY. | CHK. | APPR. |
|     | tfnrc90  | 10/19/2004              |     |      |       |

C:\vemp\AM-Work\Tfnrc90\W-Cctapetsp047.D-TDoCS-S-Template\ESI\STANDARDS\Transmission\TNSW013A0.DWG, 01/05/2005 07:26:03 AM, tfnc90, drogill

This document is the property of Entergy Services, Inc. and contains confidential and proprietary information owned by Entergy Services, Inc. Any copying, use, or disclosure of this information without the written permission of Entergy Services, Inc. is strictly prohibited. This material is protected under trade secret and unfair competition laws and the expression of the information contained herein is protected under Federal copyright laws. Violations thereof may result in criminal penalties and fines.

**Attachment 14**  
**Inspection Report, Erosion and Sediment Control Measurements**

**Critical to the success of a SWPPP are the documented procedures of inspecting and maintaining the component parts of erosion and sediment control measures. At a minimum, the inspection schedule should include:**

- 1. Routine, weekly review of all erosion and sediment control measures.**
- 2. Inspection of all erosion and sediment control measures within 24 hours of a rainfall event of ½" or more.**
- 3. Inspections shall be performed by trained personnel familiar with erosion and sediment control measures outlined in the SWPPP.**
- 4. All erosion and sediment control measures will be inspected and a log of the inspection will be kept.**
- 5. All receiving streams and discharge areas will be visually assessed, including areas where stormwater runoff from disturbed areas and product storage areas has been encountered.**
- 6. Roads, parking areas, and other areas of vehicular traffic will be inspected for possible off-site contamination sources.**
- 7. Silt fences, straw bales, sediment barriers, and ditch checks will be evaluated for continued integrity.**

**Documentation of all inspection activities will include:**

- Name of inspector, date and time of the inspection, and the results of the inspection.**
- Recommended actions relative to stormwater pollution control noted.**
- Recap of results of previous control practices and their success/failure.**
- A copy of the SWPPP should be available on the job site at all times ready to present to the inspector.**

**These inspection reports will be maintained as a record document for a period of three years from the date of the last report.**

**Any changes to the erosion and sedimentation control measures based as a result of the inspections will be in accordance with the SWPPP. Staging areas will be inspected to ensure that sediment or particulates from equipment are not reaching storm drains or ditches. Haul routes will be inspected to identify areas of erosion or excessive dust. Paved roads will be inspected to identify areas with mud, dirt, or rock that needs to be removed.**

**Maintenance actions include prompt repair of any erosion and sediment control measures found to be ineffective. This action will be taken prior to the next rain event. Documentation of required maintenance activities will be provided as described above. Sufficient supply of repair equipment and materials will be kept on hand at all times. An inspection form is included on the following page.**

**Attachment 14  
Inspection Report**

**Erosion and Sediment Control Measures**

**(To be submitted every 7 days and within 24 hours of each rainfall event of 1/2" or more.)**

Project Name: \_\_\_\_\_ CEA #: \_\_\_\_\_

Number of days since last rainfall: \_\_\_\_\_ Amount of last rainfall: \_\_\_\_\_"

Location: **(One location per report; Substation Name, Line Structure Number, Stream Name, Staging Area, Haul Route, Parking Area, Paved Road, etc.)**

Control Measure Type: **(Silt Fence, Straw Bales, Riprap, Sandbags, Filter Blanket, Matting, Slope Drain, Diversion Ditch, Rolling Dip, Water Bar, etc.)**

Condition: **( Be specific)**

Recommended Maintenance Actions:

Results of Previous Recommended Maintenance Actions:

**Copy of this report to be maintained by Entergy for not less than 3 years.**

**Inspector Signature:** \_\_\_\_\_ **Date:** \_\_\_\_\_ **Time:** \_\_\_\_\_

**Copy submitted to:** \_\_\_\_\_  
Construction Engineer

## **Appendix E**

### **Notice of Intent and Notice of Termination Forms**

**Appendix F**  
**Certification Forms**

**SITE INSPECTOR CERTIFICATION**

"I certify under penalty of law that I am knowledgeable in the principals of erosion and sediment control, who possesses the skills to evaluate conditions at the above construction site that could impact stormwater quality, and knowledgeable in the correct installation of erosion and sediment controls. I am able to assess the effectiveness of any sediment and erosion control measures selected in the SWPPP to control the quality of stormwater discharges from the above construction site. Additionally, I certify that I have reviewed the Arkansas Stormwater Construction General Permit ARR150000 and SWPPP which was prepared by the owner of this site."

Signature: Don Dillard  
Printed Name: Don Dillard  
Title: Const Management Representative  
Date: 4-23-08

**Certification must be signed prior to commencement of construction.**

## SITE INSPECTOR CERTIFICATION

"I certify under penalty of law that I am knowledgeable in the principals of erosion and sediment control, who possesses the skills to evaluate conditions at the above construction site that could impact stormwater quality, and knowledgeable in the correct installation of erosion and sediment controls. I am able to assess the effectiveness of any sediment and erosion control measures selected in the SWPPP to control the quality of stormwater discharges from the above construction site. Additionally, I certify that I have reviewed the Arkansas Stormwater Construction General Permit ARR150000 and SWPPP which was prepared by the owner of this site."

Signature: *Dennis A. McAfey Jr.*  
Printed Name: Dennis A. McAfey Jr.  
Title: Group Manager / Sr. Scientist  
Date: 4-23-08

**Certification must be signed prior to commencement of construction.**

**SITE INSPECTOR CERTIFICATION**

"I certify under penalty of law that I am knowledgeable in the principals of erosion and sediment control, who possesses the skills to evaluate conditions at the above construction site that could impact stormwater quality, and knowledgeable in the correct installation of erosion and sediment controls. I am able to assess the effectiveness of any sediment and erosion control measures selected in the SWPPP to control the quality of stormwater discharges from the above construction site. Additionally, I certify that I have reviewed the Arkansas Stormwater Construction General Permit ARR150000 and SWPPP which was prepared by the owner of this site."

Signature: \_\_\_\_\_

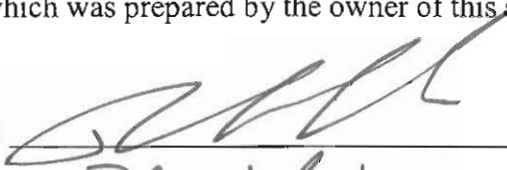

Printed Name: J. Grant Barber

Title: Sr. Scientist

Date: 4-28-08

**Certification must be signed prior to commencement of construction.**



## **Appendix G**

### **Agency Coordination**



An employee-owned company

April 23, 2008

Mr. Chris Davidson  
United States Fish and Wildlife Service  
Ecological Services  
Arkansas Field Office  
110 South Amity Road, Suite 300  
Conway, AR 72032  
(501) 513-4470

**RE: Threatened and Endangered Species Consultation/Clearance  
Entergy Services, Inc.  
Pleasant Hills to ANO Emergency Rebuild Project  
Pope County, Arkansas  
PBS&J No. 100001086**

Dear Mr. Davidson:

On February 5, 2008, a category F4 tornado (Fujita scale) destroyed seven electric transmission line towers on Entergy Services, Inc. (Entergy) existing Pleasant Hills to ANO 345kV electric transmission line in Pope County, Arkansas. The approximate midpoint of the impact area is: Latitude: 35° 16' 13" North Longitude: 92° 51' 59" West. The line service is critical, as it is a direct line to two large Electric High Voltage (EHV) yards. An EHV yard transitions electricity from power plant along a 500kV line and transmits across the state. This line in particular supplied Pleasant Hills EHV which in turn supplies Little Rock, Arkansas, and connects to the Transmission Reliability Grid covering the United States.

On February 6, 2008, President George W. Bush declared the area a national disaster area. Concurrently, Entergy began site evaluations to assess the damage and initiate recovery operations. Equipment was mobilized to the site on February 7–10, 2008, and rebuild began immediately. On February 24, 2008, the line was back in service, and by February 28, 2008 all equipment was removed. Elapsed time was 23 days.

A search of the records of the Arkansas Natural Heritage Commission's Rare Species Search Engine (RSSE) was conducted for the project area on April 22, 2008. The search was conducted to assist in restoration activities for the project with the least amount of environmental impacts. Table 1 on the following page lists the species that have been identified as potentially occurring in Pope County according to the RSSE.

During the construction activities, a qualified biologist visited the project location and did not identify the location and extent of individuals, colonies, or potential critical habitats of

federal/state listed threatened or endangered (T&E) species (within the project area) identified by the United States Fish and Wildlife Service (USFWS) and protected under the Endangered Species Act. PBS&J is requesting written documentation regarding compliance with the Endangered Species Act of 1973.

Table 1, Species potentially occurring in Pope County, Arkansas according to the RSSE search.

| Common Name               | Scientific Name                     | Status <sup>6</sup> |                  | Distance From Project Area |
|---------------------------|-------------------------------------|---------------------|------------------|----------------------------|
|                           |                                     | Federal             | State            |                            |
| Gray myotis               | <i>Myotis grisescens</i>            | LE <sup>1</sup>     | INV <sup>3</sup> | Unknown                    |
| Arkansas River Shiner     | <i>Notropis girardi</i>             | LT <sup>2</sup>     | INV <sup>3</sup> | Unknown                    |
| Interior Least Tern       | <i>Sterna antillarum athalassos</i> | LE <sup>1</sup>     | INV <sup>3</sup> | Unknown                    |
| Open-ground whitlow-grass | <i>Draba aprica</i>                 | -                   | ST <sup>4</sup>  | Unknown                    |
| Small-headed pipewort     | <i>Eriocaulon kornickianum</i>      | -                   | SE <sup>5</sup>  | Unknown                    |
| Alabama snow wreath       | <i>Neviusia alabamensis</i>         | -                   | ST <sup>4</sup>  | Unknown                    |
| Interrupted fern          | <i>Osmunda claytoniana</i>          | -                   | ST <sup>4</sup>  | Unknown                    |
| Ovate-leaved catchfly     | <i>Silene ovata</i>                 | -                   | ST <sup>4</sup>  | Unknown                    |
| Dwarf bristle fern        | <i>Trichomanes petersii</i>         | -                   | ST <sup>4</sup>  | Unknown                    |

<sup>1</sup> LE = Listed Endangered; the U.S. Fish and Wildlife Service has listed these species as endangered under the Endangered Species Act.  
<sup>2</sup> LT= Listed Threatened; the U.S. Fish and Wildlife Service has listed these species as threatened under the Endangered Species Act.  
<sup>3</sup> INV = Inventory Element; The Arkansas Natural Heritage Commission is currently conducting active inventory work on these elements. Available data suggests these elements are of conservation concern. These elements may include outstanding examples of Natural Communities, colonial bird nesting sites, outstanding scenic and geologic features as well as plants and animals, which, according to current information, may be rare, peripheral, or of an undetermined status in the state. The ANHC is gathering detailed location information on these elements.  
<sup>4</sup> ST = State Threatened; The Arkansas Natural Heritage Commission applies this term to native plant taxa which are believed likely to become endangered in Arkansas in the foreseeable future, based on current inventory information.  
<sup>5</sup> SE = State Endangered; The Arkansas Natural Heritage Commission applies this term to native plant taxa which are in danger of being extirpated from the state.  
<sup>6</sup> Source: Arkansas Natural Heritage Commission, Rare Species Search Engine, Pope County, Arkansas, (2008).

Mr. Davidson  
Entergy Services, Inc.  
Pleasant Hills to ANO Emergency Rebuild Project  
Threatened and Endangered Species Consultation/Clearance  
April 23, 2008  
Page 3 of 3

Thank you for your assistance with this project. Please contact me at (903) 509-1552 or [jgbarber@pbsj.com](mailto:jgbarber@pbsj.com) if you have any questions or require additional information.

Sincerely,

**PBSJ**



*for*

J. Grant Barber  
Sr. Scientist

**CONCURRENCE:**

---

**Authorization signature**

**Date**

cc: File

Attachments

Arkansas Department of Environmental Quality  
NPDES Branch, Water Division  
5301 Northshore Drive  
North Little Rock, AR 72218  
(501) 682-0623

---

NOTICE OF TERMINATION  
FOR DISCHARGERS OF STORM WATER RUNOFF ASSOCIATED WITH  
MEDIUM OR LARGE CONSTRUCTION ACTIVITY  
AUTHORIZED UNDER NPDES GENERAL PERMIT ARR150000

---

Permit Tracking Number to be Terminated:    **ARR15** \_\_\_\_\_

**I. PERMITTEE INFORMATION**

Permittee Name: \_\_\_\_\_ Permittee Type: \_\_\_\_\_  
Permittee Mailing Address: \_\_\_\_\_  STATE            PARTNERSHIP  
City: \_\_\_\_\_  FEDERAL            CORPORATION\*  
State: \_\_\_\_\_ Zip: \_\_\_\_\_  SOLE PROPRIETORSHIP  
Permittee Telephone Number: \_\_\_\_\_ \*State of Incorporation: \_\_\_\_\_  
Permittee Fax Number: \_\_\_\_\_

---

**II. CONSTRUCTION SITE INFORMATION**

Project Name: \_\_\_\_\_ Project Contact Person: \_\_\_\_\_  
Project County: \_\_\_\_\_ Project Physical Address: \_\_\_\_\_  
Directions to the Project: \_\_\_\_\_ Project City: \_\_\_\_\_ Zip: \_\_\_\_\_  
\_\_\_\_\_ Telephone Number: \_\_\_\_\_

Is the Contractor the same as the permittee?    Yes            No           If no, complete the appropriate information.

Name: \_\_\_\_\_ City: \_\_\_\_\_  
Address: \_\_\_\_\_ State \_\_\_\_\_ Zip: \_\_\_\_\_  
Telephone Number: \_\_\_\_\_

---

**III. PERMITTEE CERTIFICATION**

"I certify under penalty of law that all soil disturbing activities have been completed and a uniform (e.g., evenly distributed, without large bare areas) perennial vegetative cover with a density of 70% of the native background vegetation cover for the area has been established on all unpaved areas and areas not covered by permanent structures, or equivalent permanent stabilization measures have been employed, or that all storm water discharges associated with the construction activities from the identified site that are authorized by an NPDES general permit have been eliminated. I understand that by submitting this Notice of Termination that I am no longer authorized to discharge storm water by general permit, and that discharging pollutants in storm water associated with construction activity to waters of the United States is unlawful under the Clean Water Act and the Arkansas Water and Air Pollution Control Act where the discharge is not authorized by an NPDES permit."

Typed or Printed Name: \_\_\_\_\_ Title: \_\_\_\_\_  
Signature: \_\_\_\_\_ Date: \_\_\_\_\_